



# AM-5230 M-Series Audio Management Unit

>>>> **USER & SERVICE HANDBOOK**



ACMA Supplier Code **N468**

ERAC Responsible Supplier Number **E1287**

**ISO9001 Certified**

Document T17236

Issue 1.1, 17/07/2018

FOR

**Motorola Solutions Australia**



**Design Two Thousand Pty Ltd** ABN: 45 005 014 639

9-11 Rose Street

Upper Ferntree Gully

Melbourne Victoria 3156 Australia

Telephone: +613 9758 5933 Facsimile: +613 9758 5560

Email: [gen@design2000.com.au](mailto:gen@design2000.com.au)

Web Site: [www.design2000.com.au](http://www.design2000.com.au)

**All Rights Reserved,  
Copyright © 2018, Design 2000 Pty Ltd**

---

The Audio Management Unit AMU-5230M is a Fly-by-wire (FBW) design. Any button or potentiometer can be programmed to control any function. It is a digital matrix switch where any audio input can be programmed to appear at any output. Audio sources are not digitized. They are left in analogue form, amplified or attenuated by digital potentiometers via low noise, low distortion operational amplifiers to maintain the purest possible audio. In addition, audio inputs and outputs are transformer isolated that provide the required electrical isolation and prevention of ground loop hum.

*Thank You for using this Australian Engineered and Manufactured Product*

---



Est. 1968

---

<b>CUSTOMER</b>	Motorola Solutions Australia Pty Ltd
<b>ADDRESS</b>	Unit 4, 54 Sydenham Road Norwood South Australia 5067 Australia Attn.: Darren Billet / Evan Fitch / John Stradiotto

<b>CONTRACTOR</b>	Design Two Thousand Pty Ltd ABN 45 005 014 639
<b>SUPPLIER ID.</b>	0818289
<b>ADDRESS</b>	9-11 Rose Street Upper Ferntree Gully Melbourne Victoria 3156 Australia

<b>CONTENTS</b>	
AM-5230 M-Series User & Service Handbook	Sheets 8 –38
<b>Attachments:</b>	
1. AMU Terminal Config. Commands	Sheets 39 –46
2. Firmware Update Procedure	Sheets 47 – 49
3. AMU Circuit Diagrams	Sheet 50 onward



# Document Control

<b>Document ID</b>	T/17236		
<b>Document Name</b>	AM-5230 M-Series User & Service Handbook		
<b>Security</b>	Commercial in Confidence		
<b>Circulation</b>	Design 2000, Motorola Solutions Australia, SAGRN Utilities		
<b>Prepared By</b>	Peter Zeug		
<b>Reviewed By</b>	Darren Billett Evan Fitch		
<b>Approved By</b>			
<b>Version Control</b>	<b>Edition</b>	<b>Date</b>	<b>Notes</b>
	1.0	20/10/2017	M-Series SAGRN Version
	1.1	17/07/2018	Light Tower Interface added

# Document Copyright

© 2018 Design 2000 Pty Ltd. All rights reserved. No part of this publication, or any software included with it may be reproduced, stored in a retrieval system, or transmitted in any form or by any means, including photocopying, electronic, mechanical, recording or otherwise, without the prior written permission of the copyright holder.

This document contains proprietary information of Design 2000 Pty Ltd. The contents are confidential and any disclosure to persons other than the officers, employees, agents or subcontractors of the owner or licensee of this document, without the prior written consent of Design 2000 Pty Ltd is strictly prohibited.

© Copyright 2018, Design 2000 Pty Ltd

## Country of Manufacture

**AUSTRALIA**

## Manufacturer's Contact Details

**DESIGN TWO THOUSAND PTY LTD**

ABN.: 45 005 014 639

**design2000**

Est. 1968

9-11 ROSE STREET  
UPPER FERNTREE GULLY  
MELBOURNE VICTORIA 3156  
**AUSTRALIA**

Telephone: (03) 9758 5933      Facsimile: (03) 9758 5560  
International Telephone: +613 9758 5933      International Facsimile: +613 9758 5560

Email: [gen@design2000.com.au](mailto:gen@design2000.com.au)      Web Site: [www.design2000.com.au](http://www.design2000.com.au)

# Contents

SECTION	SHEET	DESCRIPTION
<b>1</b>	<b>8</b>	<b>AM-5230M High Level Description</b>
1.2	8	Overview
1.3	9	High Level AMU Architecture
<b>2</b>	<b>10</b>	<b>System Components</b>
2.1	10	Audio Management Console
2.2	10	Rack Interface
2.3	10	Under-mount Headset Connector Box
<b>3</b>	<b>11</b>	<b>Feature Set table</b>
<b>4</b>	<b>12</b>	<b>User Guide</b>
4.1	12	Talking Guide
4.1.1	12	Telephone
4.1.2	12	Radio
4.1.3	12	Voice Logger for Radio
4.1.4	12	Voice Logger for Telephone
4.1.5	13	Memo Function
4.1.6	13	Alert Tone
4.2	14	Listening Guide
4.2.1	14	Telephone
4.2.2	14	Radio
4.2.3	15	Phone or Radio Priority
4.2.4	16	Voice Logger Playback
4.2.5	16	Operator Assist
4.2.6	16	Media Audio (Music)
4.2.7	17	With both Headsets disconnected
4.2.8	17	Headset Mic Mute
<b>5</b>	<b>18</b>	<b>Connector Pin-outs</b>
5.1	18	Console Front Panel Connector Pin-outs
5.1.1	18	AUX 3 Unbalanced Media Audio Input 3.5mm stereo TRS jack
5.2	19	Console Rear Panel Connector Pin-outs
5.2.1	19	Remote PTT/Alert Switch & Console Programming Port
5.2.2	19	Rack Interface 1A
5.2.3	19	Rack Interface 1B
5.3	20	Rack Interface Front Panel
5.3.1	20	Console Front Panel Power Indicator
5.4	20	Rack Interface Rear Panel Connector Pin-outs
5.4.1	20	Footswitches & Rack Programming Port
5.4.2	20	Headsets
5.4.3	21	VPM Audio + PTT OUT + H/SET Connected
5.4.4	22	VPM PTT IN
5.4.5	22	VPM COSC
5.4.6	22	Media Audio in
5.4.7	23	Operator Assist/PA Audio & Relays out
5.4.8	23	Voice Logger Radio Audio
5.4.9	23	Voice Logger Telephone/Memo Audio
5.4.10	23	Voice Logger Audio in
5.4.11	23	Telephone Headset Adaptor
5.4.12	24	Console 1A
5.4.13	24	Console 1B
5.4.14	24	Headset Connector Box
<b>6</b>	<b>25</b>	<b>Description &amp; Operation of AMU components</b>
6.1	25	Headset Connector Boxes
6.2	25	Operator's Headset(s)
6.3	26	Speaker
6.4	26	Audio Level Meter
6.5	26	PTT Button
6.6	27	Alert Tone
6.7	28	Priority Control

6.8	29	Media Auxiliary Audio Inputs
6.9	30	PIP Tones
6.10	30	PA Functionality
6.11	31	Memo Recording
6.12	31	Activity Indicators
6.13.1	31	Tx
6.13.2	31	Rx
6.13.3	31	LOG
6.13	32	Voice Logging Ports
6.14	33	AMU Telephone Audio
6.14.1	34	3V Off Hook Adaptor for Alcatel-Lucent Telephones
6.14	35	Light Tower Interface Box
<b>7</b>	<b>37</b>	<b>Warranty</b>
<b>A1</b>	<b>39</b>	<b>Terminal Configuration Commands</b>
A1.1	39	Connecting an ANSI Terminal to the AMU
A1.2	39	AMU to ANSI Terminal Interface Cable
A1.3	42	Audio Level Adjustments
A1.4	42	Audio Level Meter
A1.5	42	Media Aux. Audio Auto Mute Timer
A1.6	42	Feature Enable/Disable
A1.7	43	Logging Playback Mute Timer
A1.8	43	Priority Control Behavior
A1.8.1	44	Alternate Priority Control Functionality
A1.9	44	General Features
A1.10	45	AMU Settings Dump
A1.11	46	AMU Service Mode Input Errors
A1.12	46	AMU Level Meter Mode
A1.13	46	AMU Settings back to Default
A1.14	46	AMU Soft Reboot
<b>A2</b>	<b>47</b>	<b>Firmware Update Procedure</b>
A2.1	47	In-Circuit Firmware Programmer
A2.2	48	Updating the Firmware
A2.2.1	48	Installing the Programmer Software
A2.2.2	48	Uploading New Firmware to the Rack or Console
<b>A3</b>	<b>49</b>	<b>Specifications</b>
<b>A4</b>	<b>50</b>	<b>Circuit Diagrams</b>
		Console
		Rack Interface
		Headset Connector Box

---

# 1. Audio Management Console

Model AM-5230M

## 1.1 High Level Description

The Audio Management Unit (AMU) is a semi-automatic audio control panel and audio mixer for Radio and Telephone Operators.

Its purpose is to make using the radio and telephone for dispatch operations an uncomplicated, straightforward procedure. It also allows Radio Operators to listen to media audio such as a TV set, radio station or personal music player during idle periods.

The main Console has push button selectors, volume controls and LED indicators that provide easy access to the radio network and the telephone network. The Console connects to a Rack interface that interconnects headsets, footswitches, media audio sources, telephone, PA system, voice recorders (loggers), and the Motorola MCC 7500 Dispatch Console with Voice Processor Module.

## 1.2 Overview

This document provides User instructions and Service information for the Audio Management Unit (AMU) interfaced to a Motorola MCC7500 VPM based console and an end customer's telephone system.

The MCC7500 Console consists of a Voice Processing Module (VPM) and a PC running the elite application. The VPM connects to the ASTRO P25 radio system, providing an Operator analogue audio into or out of the system, and provides encryption/decryption of that audio. The elite application provides the Operator with a visual display of radio resources and their associated activity.

The AMU connects to the VPM and end customer telephone network, completing both radio & telephone analogue audio paths. The AMU consists of an audio management Console, two headset boxes, an optional remotely mounted PTT/Alert switch and a Rack interface. The Rack interface connects to the VPM and to the end customer's desktop telephone, providing an audio interface between either the VPM or desktop telephone and all other devices. The audio management Console provides a physical user interface to the Operator, allowing them to control how audio is managed by the AMU.

In this document the term *User* or *Operator* refers to an ever day user who uses the AMU to connect to the radio and telephone systems to perform work duties. The term *Service User* refers to a technician who configures or adjusts the way the AMU functions, but does not use the AMU on an ever day basis.

See next page for AMU high level architecture diagram.



# 1.3 High Level AMU Architecture

The AMU components are shown in grey:

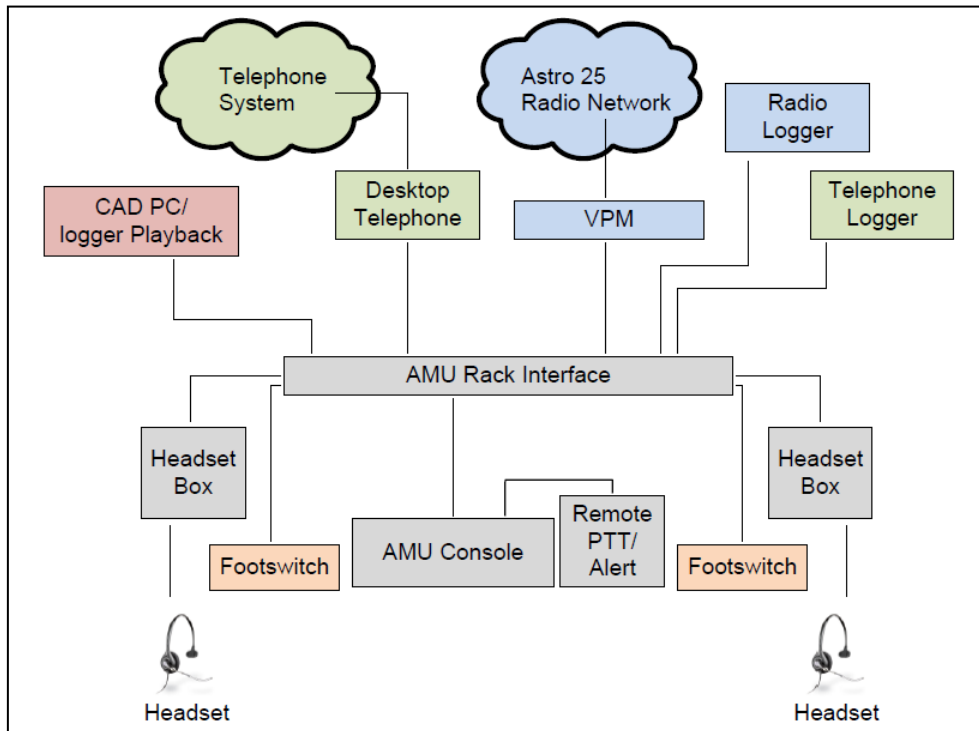
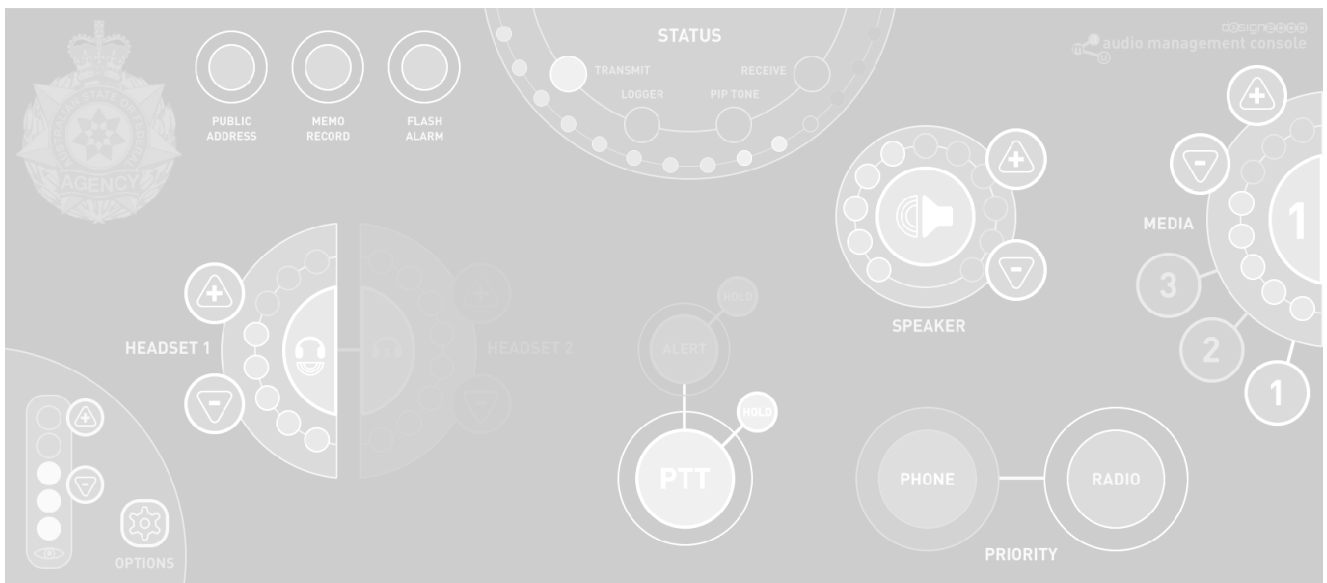

Figure 1.3.1 – AMU High Level Architecture



# 2. AMU System Components

## 2.1 Audio Management Console



This is the Radio Operator’s user interface with push button selectors, volume controls, audio level meter and speaker. It is mounted on a 45° sloping desk mount stand with non-slip rubber feet. The total height is 112mm.

## 2.2 Rack Interface

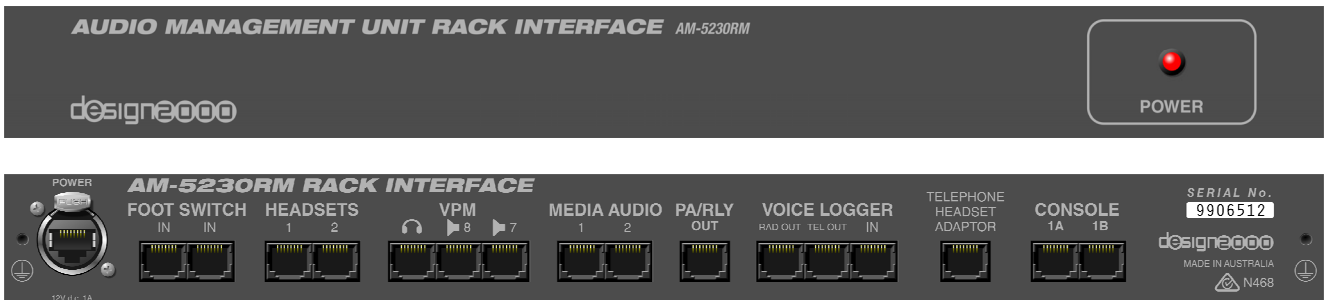

This interfaces the Audio Management Console to the Motorola MCC 7500 Dispatch Console with Voice Processor Module. It also has the connectors for power input (NE8FDP-R RJ45 socket assembly with NE8MC plug housing), footswitches, media audio in, PA audio out, Logging audio in / out, headset connector boxes and telephone analogue audio.

## 2.3 Under-mount Headset Connector Boxes

The Headset Connector Boxes have a 4P4C RJ22 connector to allow the connection of a headset in a convenient, accessible under-desk location.

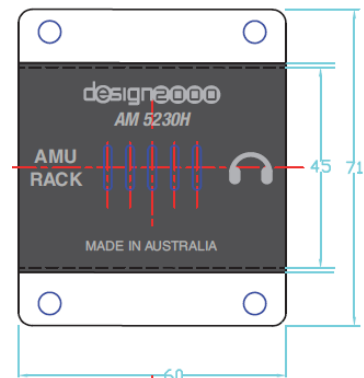

# 3. AMU Feature Set Table

(C) = on Console  
(R) = on Rack Interface

FEATURE	AM-5230M
<b>System Features</b>	
Spilt system Console (3RU) & Rack Interface (1RU 19")	√
Mounting brackets for standard 19" rack mounting (R)	√
12V d.c. SELV powered (R)	√
Locking power connector (NE8FDP-R RJ45 supplied with NE8MC plug (R)	√
Under-mount Headset Connector boxes (two)	√
Detect PTT from compatible headsets (6-wire)	√
Automatic ducking of telephone or radio audio	√
Automatic music/TV audio during idle periods	√
Automatic muting of music during phone or radio activity	√
Can send record pips to telephone line & voice logger	√
Pip tone during recording telephone calls 1.4kHz 425ms to Australian Standard AS/CA S002:2010 section 5.8	√
Alert tone 800/1500 Hz sine wave IMBE/AMBE vocoder friendly. Other tones to order	√
Adjustable minimum and maximum audio levels for headsets and speaker	√
Auxiliary and Media audio can be routed to the speaker	√
Radio and Telephone audio can be routed to single log output	√
Light Tower Interface Box (Optional)	√
Firmware upgradable in the field. All settings are Service user-adjustable	√
<b>Console Features</b>	
Audio Level meter bar graph, configurable for monitoring speaker, headset, mic and music levels (C)	√
Receive (Rx) LED indicator (C)	√
Inbuilt PTT (Tx) Push Button and Alert Tone Push Button	√
PTT (Tx) LED Indicator, illuminates with PTT button, footswitch PTT and VPM initiated PTT (C)	√
Phone or Radio Priority illuminated buttons (C)	√
Media audio illuminated buttons (C)	√
Individual headset radio mute on/off illuminated buttons (C)	√
Individual headset volume controls (C)	√
Headset disconnect function support	√
Headset(s) disconnected indication (C)	√
Front panel media audio input x 1 (C). 3.5mm stereo mini jack for iPod or similar	√
Media audio volume control (common to all) (C)	√
Audio peak limiter to AS/ACIF S004:2013 standard and ACIF G616:2013	√
Hardware audio limiter to AS/NZS 60950, ACA TS 006 Clause 5.2.2 (no possibility of acoustic shock)	√
Memo record illuminated button (C)	√
Operator Assist audio output illuminated button (C) (can optionally generate an output to any spare relay)	√
Voice Log recording in progress LED. Lights up for radio, telephone and memo recording (C)	√
Inbuilt monitor speaker (C)	√
Speaker volume control (C)	√
Supervisor Mode – allows for direct conversation between both headsets	√
Custom silk screen with logos / graphics as required	√
Stand-alone angled desktop console stand (120mm high, 45° angle & textured black)	√
<b>Rack Interface Features</b>	
Dual headset interfaces (RJ45) (R)	√
Dual PTT footswitch interfaces (RJ45) (R)	√
VPM Headset, PTT and Channel Activity Interfaces (RJ45 x 3)	√
Isolated (inbuilt LIU) telephone audio port (RJ45). Four wire analogue. Complies with AS/NZS 60950 (R)	√
Media audio inputs (RJ45 x 2) (R). eg. for TV or AM/FM/DAB+ audio	√
Radio & Telephone/Memo Voice Logger audio and relay control outputs (RJ45 x 2) (R)	√
Voice Logger Playback input ports x 2 (RJ45)	√
Operator Assist (PA) audio output (RJ45) (R)	√

Table 3.1 – AMU Features

# 4. User Guide

## 4.1 Talking (Transmit) Guide

### 4.1.1 Telephone

To talk using the telephone, the telephone handset must be lifted off hook (picked up). The Operator then speaks into the headset microphone and audio is sent to and from the telephone network. If the Operator holds down the PTT button while talking on the phone, the audio from the headset mic will switch from the phone to the radio.

### 4.1.2 Radio

To talk via the radio, press and hold down the PTT button on the front panel or operate the foot-switch. It is not possible to talk via the headset to the phone and the radio at the same time. The green Tx LED lights up whenever PTT is engaged.

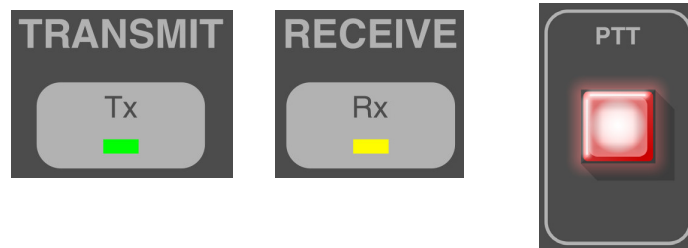

### 4.1.3 Voice Logger for Radio

The continuous logger for radio records audio from the microphone whenever the radio (PTT button, foot-switch or VPM PTT) is active (indicated by the green Transmit LED), or when a channel is active (indicated by the yellow Receive LED on). Voice Log recording is indicated by the red LOGGER ACTIVE LED. The Service user can also log radio audio on the telephone logger.

### 4.1.4 Voice Logger for Telephone

The continuous logger for phone records audio from the headset microphone whenever the phone is off hook. The remote telephone party is also recorded whenever the phone is off hook. Voice Log recording is indicated by the red LOGGER ACTIVE LED. It is also possible for the AMU to send PIP tones to the telephone party indicating that the call is being recorded.



#### 4.1.5 Memo Function

If enabled by the Service User, the Operator can record an audio memo on the TEL OUT voice logger by pressing and holding the MEMO RECORD button on the front panel. The MEMO RECORD button lights up whenever it is being pressed to indicate that the logger is recording.



#### 4.1.6 Alert Tone

The Operator can send an Alert tone to air by pressing and holding down the ALERT TONE Button. Standard tone for the SAGRN is:

1. Alternating 800/1500 Hz sine wave.  
Each tone burst is 250 ms long.

All Tones are sine wave IMBE / AMBE vocoder friendly.  
Other tone sequences are available on request.



## 4.2 Listening (Receive) Guide

### 4.2.1 Telephone

The phone audio can be heard on the headsets only, and is only present when the phone is off hook.

### 4.2.2 Radio

The Operator has a choice of listening to the radio from the console speaker and/or the headset(s). There are volume controls for each of the two headsets and the speaker. If the feature is enabled by the Service User, pressing the Headset RADIO AUDIO MUTE button so that the LED turns yellow/orange will disable the mic Tx audio from the headset. If either or both headsets are unplugged, the corresponding push button will turn RED to indicate that they are disconnected. The radio audio will always be heard from the console speaker unless it is also turned off or down. Whenever radio audio is being received by the AMU, the RECEIVE Rx LED will light up.

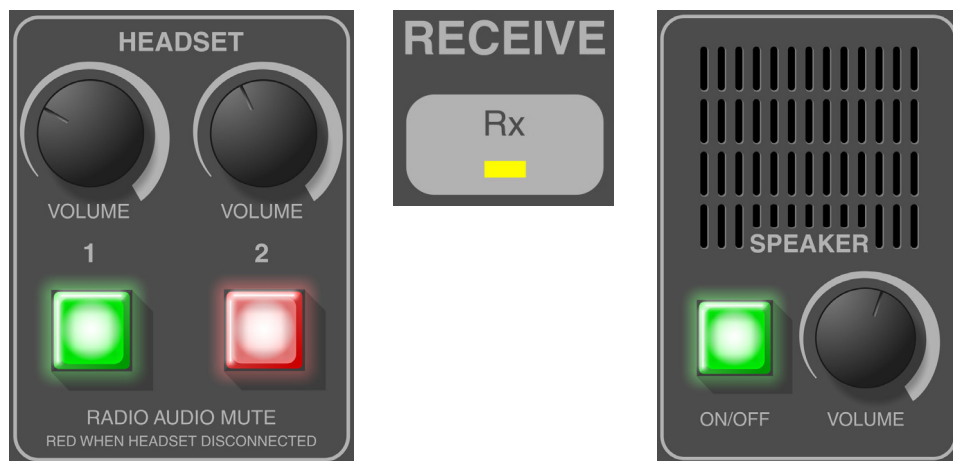

### 4.2.3 Phone or Radio Priority

The phone priority (blue) and radio priority (blue) buttons allow the Operator to select which of the two audio inputs is to be heard at the higher volume level when both inputs are active. The ways in which the Priority buttons operate are Service User configurable but in simple terms we have:

1. Radio Priority (when Radio Priority button is pressed and illuminated):  
The radio is louder than the phone when both calls are in progress.
2. Telephone Priority (when Phone Priority button is pressed and illuminated):  
The phone is louder than the radio when both calls are in progress.
3. Automatic Priority (when both priorities are selected):  
In the automatic mode the AMU automatically alternates between priorities depending on which source comes in first. If telephone call is established, any radio audio is 'ducked' into the background for the duration of the telephone call. If a radio call is established, any telephone audio is ducked into the background until the radio call is over and out.

Automatic Priority (when both priorities are unselected):  
All audio sources are heard at normal level with no ducking.

*There is a Service User option to set Alternate Priority Control functionality where Phone Priority mutes the radio and Radio Priority mutes the phone.*

The priority audio source (radio or telephone) is only relevant when both are active. The moment one audio source is idle; the other audio source will be heard at the normal higher level.



#### 4.2.4 Voice Logger Playback

The Logger playback is heard through the headset(s) and speaker at the volume manually controlled by the headset volume controls and the speaker volume control.

#### 4.2.5 Operator Assist

If enabled by the Service User, the Operator can call for Assistance by activating a Light Tower and make announcements over a PA system by pressing and holding the OPERATOR ASSIST button on the Console panel. The button will illuminate while it is being pressed and all Headset mic audio is sent to the PA. To stop sending audio to the PA, release the OPERATOR ASSIST button and the inbuilt LED will go out. The Service User can also program the OPERATOR ASSIST button to latch and toggle between on and off each time the button is pressed.

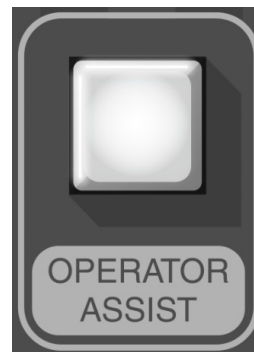

#### 4.2.6 Media Audio (Music, TV etc.)

To listen to music, press any one of the MEDIA AUDIO buttons. The volume of the music is controlled by the MEDIA AUDIO volume control. Music automatically turns off when PTT is active, radio audio is received and/or whenever the phone is off hook. When radio and phone activity returns to idle, the selected music source is automatically restored after 15 seconds. This timer and the ways in which the MEDIA AUDIO buttons function during the delay before music is automatically restored are configured by your Service User. Normally, pressing any MEDIA AUDIO button during this period will disable all media audio until one is selected again.





#### 4.2.7 With both Headsets disconnected

With both headsets disconnected, only audio from the radio and the voice loggers will be heard from the speaker. The Service User can also enable media audio to be played through the speaker. If either or both headsets are unplugged, the corresponding normally green headset push button(s) will turn RED to indicate that they are disconnected.

All input audio to the AMU will continue to be displayed on the audio LEVEL meter.



#### 4.2.8 Headset(s) Mic Mute

If a Headset mic button is green, the Operator User can press the corresponding Headset button and it will turn YELLOW/ORANGE. This completely mutes the Operator's Headset Mic for private conversations between collocated Operators.

# 5. AMU Connector Pin-outs

## 5.1 Console Front Panel



Figure 5.1.1 – AMC Front Panel Diagram

*Console has mounting brackets for 19" rack mounting or desk mounting*

### Console Front Panel Connector Pin-outs

#### 5.1.1 AUX 3 Unbalanced Media Audio Input 3.5mm stereo TRS jack

Pin Number	Description	Level / Sensitivity
Tip	Left audio	-10 dBu (693 mV p-p) (245 mV RMS) nom.
Ring	Right audio	-10 dBu (693 mV p-p) (245 mV RMS) nom.
Sleeve	Analogue Ground	0VA



## 5.2 Console Rear Panel

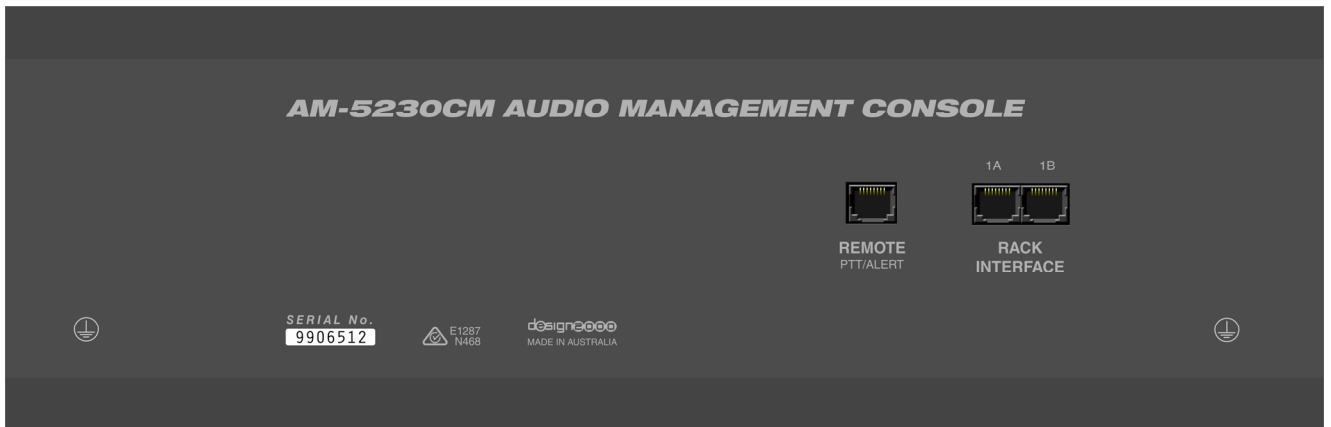

Figure 5.2.1 – AMC Rear Panel Diagram

### Console Rear Panel Connector Pin-outs

#### 5.2.1 Remote PTT/Alert Switch & Console Programming Port 8P8C RJ45

Pin Number	Description	Level / Sensitivity
1	Service Mode enable	Short to pin 4
2	Firmware update voltage	Programming Voltage (VPP) (8V)
3	Alert Tone	Contact closure to pin 6 on ALERT
4	Common to pin 5 (also Service Mode return)	0VD
5	PTT	Contact closure to pin 4 on PTT
6	Common to pin 3	0VD
7	Firmware update clock	Programming Clock (PGC)
8	Firmware update data	Programming Data (PGD)



#### 5.2.2 Rack Interface 1A 8P8C RJ45

Pin Number	Description	Level / Sensitivity
1	Tx Data	RS232
2	Digital ground	0VD
3	Analogue Ground	0VA
4	Analogue Ground	0VA
5	Power	+12V
6	Power	+12V
7	Rx Data	RS232
8	Digital Ground	0VD



#### 5.2.3 Rack Interface 1B 8P8C RJ45

Pin Number	Description	Level / Sensitivity
1	Aux 3 Input	-10 dBm (693 mV p-p) (245 mV RMS) nom.
2	Aux 3 return	0VA
3	Meter audio return	0VA
4	Analogue Ground	0VA
5	-	-
6	Meter Audio +	Meter drive
7	Speaker -	Speaker return
8	Speaker +	Speaker drive

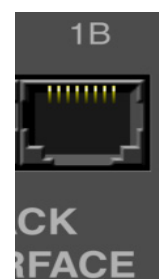

## 5.3 Rack Interface Front Panel

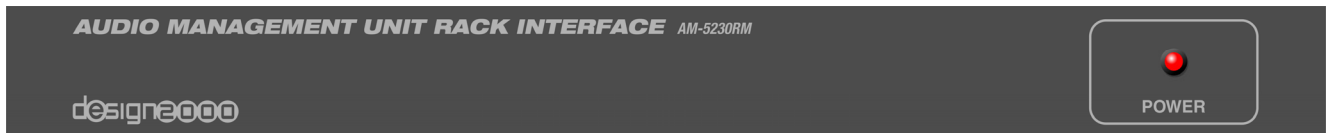

Figure 5.3.1 – Rack Interface Front Panel Diagram

*Rack Interface is supplied with mounting brackets for 19" rack mounting or desk mounting*

### 5.3.1 Console Front Panel Power Indicator

Red Power LED which illuminates whenever the AMU has 12V d.c. nom. power applied.

## 5.4 Rack Interface Rear Panel

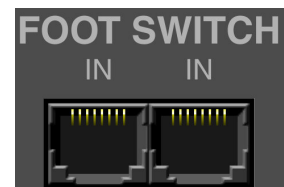

Figure 5.4.1 – Rack Interface Rear Panel Diagram

### Console Rear Panel Connector Pin-outs

#### 5.4.1 Footswitches & Rack Programming Port 8P8C RJ45

Pin Number	Description	Level / Sensitivity
1	-	
2	Firmware update voltage	Programming Voltage (VPP) (8V)
3	PTT	Normally Open
4	Digital Ground	0VD
5	Rx data	RS232
6	Tx data	RS232
7	Firmware update clock	Programming Clock (PGC)
8	Firmware update data	Programming Data (PGD)



#### 5.4.2 Headsets 8P8C RJ45 (connected to Headsets via AM-5230H Jack box)

Pin Number	Description	Level / Sensitivity
1	Connected N/C	Normally closed, switched to pin 2
2	Connected common	Common to pin 1
3	Microphone -	Microphone return
4	Speaker -	Speaker return
5	Speaker +	Speaker drive
6	Microphone +	5.6V bias, 160 mV p-p (5.6mV RMS) (-23dBu) max. -34dBu nom.
7	-	
8	-	

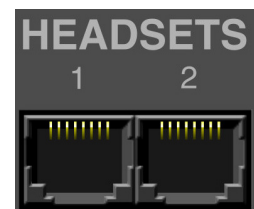

### 5.4.3 VPM Audio + PTT OUT + H/SET Connected (J2) 8P8C RJ45

Pin Number	Description	Level / Sensitivity
1	PTT out to VPM	Normally Open, switched to pin 2
2	PTT Common	Common to pin 1
3	Tx Audio	-10 dBm (693 mV p-p) (245 mV RMS) nom.
4	Rx Audio return	0VA
5	Rx Audio	-10 dBm (693 mV p-p) (245 mV RMS) nom.
6	Tx Audio return	0VA
7	Head Set Connected	Normally closed, switched to pin 8
8	Connected common	Common to pin 7

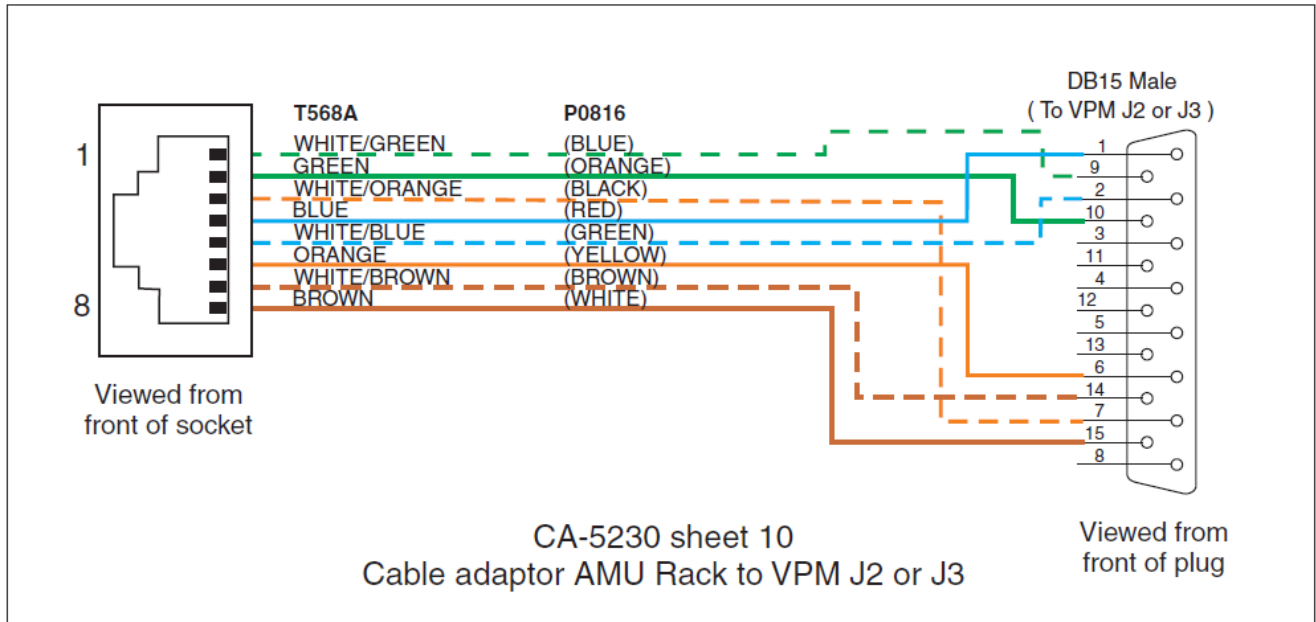
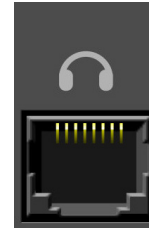

Figure 5.4.3.1 – AMU RJ45 to VPM DB15 Adaptor

#### VPM Headset Connector (DB15, J2 and J3)

Pin	Signal Name	Direction (VPM)	Function
1	Radio Audio (-)	Output	Radio Audio Out, 600 balanced, transformer isolated.
2	Radio Audio (+)	Output	
3	GND Filtered		
4	Phone Audio (-)	Output	Telephone Audio Out, 600 balanced, transformer isolated.
5	Phone Audio (+)	Output	
6	Audio In (-)	Input	Microphone Audio In, 600 balanced, transformer isolated.
7	Audio In (+)	Input	
8	A-GND		
9	PTT In (+)	Input	Contact closure input with Optocoupler. Input triggered by shorting signals together with relay.
10	PTT In (-)	Input	
11	12V		
12	A-GND		
13	HS_ST_1	Output	Headset Sidetone logic signal. Driven low by N channel MOSFET with 100 resistor in series. No Pull up network on VPM side.
14	Headset Connect In (+)	Input	Contact closure input with Optocoupler. Input triggered by shorting signals together with relay.
15	Headset Connect In (-)	Input	

#### 5.4.4 VPM PTT IN (SPKR 8) 8P8C RJ45

Pin Number	Description	Level / Sensitivity
1	PTT in from VPM	Contact closure to pin 8
2	-	
3	-	
4	-	
5	-	
6	-	
7	-	
8	PTT return	Common to pin 1



#### 5.4.5 VPM COSC (SPKR 7) 8P8C RJ45

Pin Number	Description	Level / Sensitivity
1	Call on Selected Channel (COSC)	Contact closure to pin 8
2	-	
3	-	
4	-	
5	-	
6	-	
7	-	
8	COSC return	Common to pin 1

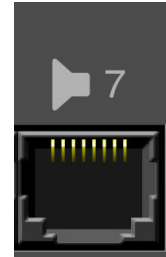

#### 5.4.6 Media Audio in 8P8C RJ45

Pin Number	Description	Level / Sensitivity
1	-	
2	-	
3	-	
4	Analogue ground	0VA
5	Audio (L/mono)	-10 dBm (693 mV p-p) (245 mV RMS) nom.
6	Audio (R)	-10 dBm (693 mV p-p) (245 mV RMS) nom.
7	-	
8	-	

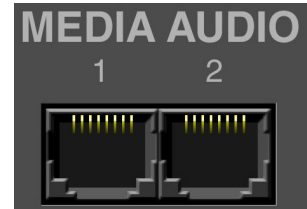

#### 5.4.7 Operator Assist/PA Audio and Relays out 8P8C RJ45

Pin Number	Description	Level / Sensitivity
1	PA Relay Out COM	Common to pin 2
2	PA Relay Out N/O	Contact closure to pin 1 on Operator Assist press
3	Mic audio out to PA	-10 dBu (693 mV p-p) (245 mV RMS) nom.
4	-	
5	-	
6	Analogue ground	0VA
7	Strobe RLY Out COM	Contact closure to pin 8 on Phone off hook
8	Strobe RLY Out N/O	Common to pin 7

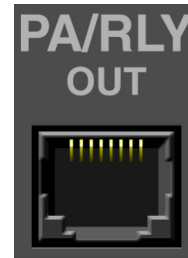

#### 5.4.8 Voice Logger Radio Audio 8P8C RJ45

Pin Number	Description	Level / Sensitivity
1	Radio activity N/O	Contact closure to pin 2 on Tx or Rx
2	Radio activity return	Common to pin 1
3	Radio audio out	-10 dBm (693 mV p-p) (245 mV RMS) nom.
4	-	
5	-	
6	Radio audio return	0VA
7	-	
8	-	

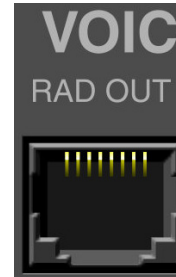

#### 5.4.9 Voice Logger Telephone/Memo Audio 8P8C RJ45

Pin Number	Description	Level / Sensitivity
1	Telephone/Memo activity N/O	Contact closure to pin 2 on Phone Off-hook or Memo button active
2	Telephone/Memo activity return	Common to pin 1
3	Telephone / Memo audio out (Service User config. for Radio)	-10 dBm (693 mV p-p) (245 mV RMS) nom.
4	-	
5	-	
6	Audio Return	0VA
7	-	
8	-	



#### 5.4.10 Voice Logger Audio in 8P8C RJ45

Pin Number	Description	Level / Sensitivity
1	Logger audio in	-10 dBm (693 mV p-p) (245 mV RMS) nom.
2	Logger audio return	Analogue ground
3	PC Alert audio in (R) isolated in parallel with pin 6	-10 dBm (693 mV p-p) (245 mV RMS) nom.
4	Sound Card Ground	Analogue ground
5	PC sound card audio in (L/mono)	-10 dBm (693 mV p-p) (245 mV RMS) nom.
6	PC sound card audio in (R)	-10 dBm (693 mV p-p) (245 mV RMS) nom.
7	PC Alert audio in (L/mono) isolated in parallel with pin 5	-10 dBm (693 mV p-p) (245 mV RMS) nom.
8	PC Alert audio return	Analogue ground

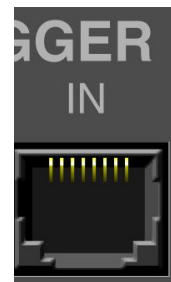

#### 5.4.11 Telephone Headset Adaptor 8P8C RJ45 (Connection to telephone)

Pin Number	Description	Level / Sensitivity
1	-	
2	-	
3	Microphone -(audio to AMU from telephone spkr)	Rx return
4	Speaker - (audio from AMU to telephone mic)	Tx return
5	Speaker + (audio from AMU to telephone mic)	Tx audio -34 dBm (43.7 mV p-p) (15.5 mV RMS) nom. (Up to 1.8V p-p)
6	Microphone + (audio to AMU from telephone spkr)	Rx audio -19.72 dBm (226 mV p-p) (80 mV RMS) nom. (Up to 1.8V p-p)
7	Off-hook N/O	Contact closure to pin 8 on Phone Off-hook
8	Off-hook common	Common to pin 7

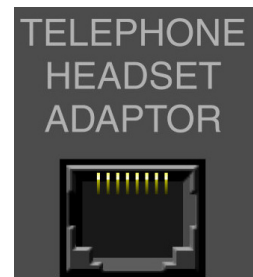

### 5.4.12 Console 1A 8P8C RJ45

Pin Number	Description	Level / Sensitivity
1	Rx Data	RS232
2	Digital ground	0VD
3	Analogue Ground	0VA
4	Analogue Ground	0VA
5	Power	+12V
6	Power	+12V
7	Tx Data	RS232
8	Digital Ground	0VD

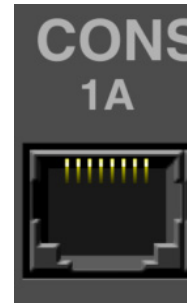

### 5.4.13 Console 1B 8P8C RJ45

Pin Number	Description	Level / Sensitivity
1	Aux 3 Input	-10 dBm (693 mV p-p) (245 mV RMS) nom.
2	Aux 3 return	0VA
3	Meter audio return	0VA
4	Analogue Ground	0VA
5	-	-
6	Meter Audio +	Meter drive
7	Speaker -	Speaker return
8	Speaker +	Speaker drive

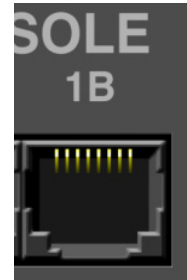

### 5.4.14 Headset Connector Box 8P8C RJ45 to Headset Connector Box 6P6C RJ12 or 4P4C RJ22

RJ45 Pin No.	Description	Level / Sensitivity	RJ12 Pin No.	RJ22 Pin No.	Description
TO AMU			TO H/S	TO H/S	
1	Connected N/C	Normally closed, switched to pin 2			
2	Connected common	Common to pin 1	1		Connected N/C
3	Microphone -	Microphone return	2	1	Speaker -
4	Speaker -	Speaker return	3	2	Microphone -
5	Speaker +	Speaker drive	4	3	Microphone +
6	Microphone +	5.6V bias, 160 mV p-p (5.6mV RMS) (-23dBu) max., -34dBu nom.	5	4	Speaker +
7	-		6		Connected common
8	-				

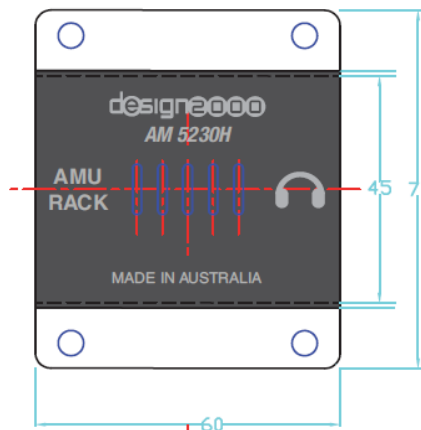

Figure 5.4.14.1 – AMU Headset Connector Box Plan View



# 6. Description & Operation of AMU System Components

## 6.1 Headset Connector Boxes

The Console Operator talks through the AMU via a headset. This headset provides the Operator access to the radio and telephone systems. The headset connects via an easily accessible headset connector box, located separately to the AMU. To add to the ease of use, the headset jack box offers only one connector that can easily be connected to without the Operator having to examine the box.

To allow a supervisor to quickly and easily connect into the AMU (alongside the Operator), a second headset box is supplied. The second headset box is identical to the first headset box, but be located on the other side of the desk.

The box size is minimised to reduce likelihood of 'knee banging' or other knee damage. The box is also designed in a way to reduce the impact of liquid spills either entering or collecting in the box (for example, if a coffee is spilt on the desk, and then runs into the box).

The existing headsets use a four pin connection. The AMU supports detection of headset connection/disconnection by detecting a voltage change to the headset microphone whenever it is plugged in.

## 6.2 Operator's Headset(s)

Once connected, the headset requires little Operator interaction to function. The Operator does not need to enable a headset; instead they only need to adjust the volume. The AMU supports the ability to mute radio audio going to the headset, removing the radio signal from the earphone but not affecting any other signal to or from the headset (i.e. microphone, telephone, logger playback and media are unaffected). It is possible for a Service User to disable this radio mute feature such that the headset always has radio audio present in the earphone (and when the AMU is first powered up). The Operator can also mute their mic.

The headset disconnect function is a feature used in this implementation of the AMU. The Operator sees the headset indicator change from green to red when a headset is disconnected from the quick disconnect connector or the headset connector box.

The AMU provides a sidetone signal (low level audio from the headset microphone) back into the headset earphone. The sidetone signal gives the Operator an indication that their microphone is working. The AMU produces adjustable sidetone level for the telephone and radio systems, and it is possible for these levels to be independently adjusted or disabled. This allows for the case where the telephone system already provides a sidetone (and the AMU telephone sidetone is reduced to zero) but the radio system has no side tone (requiring the AMU to still provide side tone).

The AMU supports two headsets. There are separate connections, volumes levels and mic mute functions for each headset.

Headset earphones provide Telephone, Radio, Media/Auxiliary, PC and logging playback audio to the Operator.

## 6.3 Speaker

The inbuilt speaker provides audio from the radio and the logger playback input. These audio inputs are always present at the speaker, unless the speaker is turned off. The Speaker on/off button displays the status of the speaker (illuminated green is on). The volume of speaker is adjustable, but this does not affect the volume of other parts of the system (e.g. logger playback audio into the headset). Media audio can also be routed to the speaker.

## 6.4 Audio Level Meter

The Audio Level Meter is a LED bar graph representing the level of the audio received by the AMU. The meter shows the loudest audio from all inputs into the AMU. Audio sources shown on the meter include:

- Both headset microphones
- Telephone receive audio
- Radio receive audio
- The selected media/auxiliary audio
- Logging playback input

It is possible to selectively disable different audio sources from displaying on the meter, to assist a Service User in adjusting and calibrating levels.

The Audio Level Meter does not change when the Operator adjusts their user volume controls.

## 6.5 PTT Button

The PTT button is used to key the selected radio resource on the MCC7500 console. The Alert button can send out an Alert tone on the selected radio resource for the time it is pressed.

When a PTT is initiated by pushing the button, it keys the radio system and sends microphone audio to the radio system. When a telephone call is in progress, initiating a PTT will send the microphone audio to the radio system and never to the telephone system for the duration of the PTT.

## 6.6 Alert Tone

The AMU generates an alert tone which is sent out to the radio system when the Alert Button is pressed. The tone is alternating 800/1500 Hz sine wave (250ms each tone), designed to be compatible with the IMBE and AMBE vocoder to maximise tone audio quality.

The alert tone is sent to the radio channel, along with a PTT signal which keys up the VPM. The radio 'Tx' activity indicator lights up, informing the Operator that a radio transmission of the tone is under way. The alert tone is also present in the Operator headset and on the speaker.

## 6.7 Priority Control

Priority Control gives the Operator options on how to manage the radio and telephone audio during simultaneous radio and telephone calls. The facility allows either radio or telephone calls to be given priority when both are active. The audio source with priority remains at an unchanged audio level, while the lesser priority audio source is reduced in audio level ('ducked' to a background level or muted).

The AMU has a priority button for both telephone and radio sources. All four combinations of priority buttons may be possible depending on how the Service User has set up the system.

Basically we have:

1. Radio Priority
2. Telephone Priority
3. Automatic Priority

In the automatic mode (both priorities selected or both priorities unselected) the AMU automatically alternates between priorities depending on which source comes in first. If telephone call is established, any radio audio is 'ducked' into the background for the duration of the telephone call. If a radio call is established, any telephone audio is ducked into the background until the radio call is over and out.

- Phone priority only selected: Phone activity will reduce the level of all radio receive audio for the duration of the phone activity.
- Radio priority only selected: Radio receive activity will reduce the level of all telephone receive audio for the duration of the radio receive activity.
- Both phone and radio priority selected: First in first out. Here the priority automatically toggles. An active source will be the priority source, eg. if the phone is active, all incoming radio receive audio is reduced in level. If the radio receive audio is active, all telephone receive audio is reduced in level.
- Neither phone nor radio selected: no audio ducking takes place.
- Service User option to set Alternate Priority Control functionality where Phone Priority mutes the radio and Radio Priority mutes the phone.

## Priority Control Service Mode Options:

- The AMU defaults to radio priority on power up
- Service User can disable the state where neither priority can be selected (at least one must have priority/be selected).
- Service User can disable the state where both priorities can be selected. By default this state is enabled.
- Radio priority: level of phone ducking is adjustable, including disabling phone audio on radio activity.
- Phone priority: level of radio ducking is adjustable, including disabling radio audio on phone activity.
- Both priorities selected: the same behavior as for radio priority (duck/disable phone on radio activity).
- Service User option to set AMU to automatic first in/first out (first in is given priority until the next first in, either radio or phone) mode for the state when both priorities are selected. If this option is not selected, the AMU defaults to radio priority.
- Service User option to set Alternate Priority Control functionality.

## 6.8 Media/Auxiliary Audio Inputs

The Media/Auxiliary (aux) audio inputs allow the Operator to listen to other audio sources when idle, including TV, AM/FM/DAB+ Radio, or a personal music device. Only one input can be active at a time.

Upon radio or telephone activity, the selected Media/Auxiliary input is temporarily muted for the call duration and then automatically re-enabled after 15 seconds (Service User programmable) of no call activity.

Three inputs are available for selection on the front panel by way of push buttons that illuminate green to notify the Operator when they are active.

Aux 3 is a 3.5mm unbalanced stereo jack (mini-jack or mini TRS jack) located on the AMU Console panel, to allow an Operator to connect a portable music device. The stereo input is mixed together to form a mono signal in the Operator's headset. It is possible for a Service User to disable this input from being used or selected.

Only one aux input can be selectable at one time and behavior is as follows:

- When pressing the button for a given input, that input's button lights up to show it is selected.
- When one aux input is already selected, pressing another aux input button will switch over to the new input.
- When one aux input is already selected, pressing the same button will disable that input.

During the temporary mute cycle, behavior is as follows:

- When temporarily muted due to call activity, the selected aux input button remains lit.
- When temporarily muted, pressing ANY aux button (selected or non-selected) will deselect the selected aux input, extinguishing the indicator and resetting the 15 second auto restore. If no button is pressed during this 15 second period, all aux inputs remain unselected and no aux audio will auto-restore.
- If a temporarily muted input was deselected during the 15 second period (as above), pressing a button to select any aux input instantly selects and enables that input (overriding the 15 second muting cycle).
- If a temporarily muted input was deselected during the 15 second period then any input was selected (as above), radio or telephone activity will keep the newly selected input muted. The newly selected input button will light up, but audio will not restore until a new 15 second period of inactivity has expired.

## 6.9 PIP Tones

The AMU is capable of generating PIP tones to be sent out onto the telephone system to indicate that recording is taking place. By default, PIP tones are disabled.

PIP tones are generated as described in AS/CA S002:2010 section 5.8.

If enabled, PIP tones are only generated while the telephone is off hook and are only sent to the remote telephone party. It is only the remote telephone party that may be unaware of their call being recorded. PIP tones may be legislated and are a method for notifying callers that their conversation is being recorded and logged for future recall.

PIP tones are 425ms bursts of 1.4kHz repeated every 15 seconds. They are not louder than -23 dBm into 600 Ohms.

## 6.10 PA Functionality

The AMU supports the ability to send Headset microphone audio to a Public Address (PA) system.

When enabled, pressing and holding the Operator Assist button sends microphone audio from both headsets to the PA port of the AMU rack interface. No other audio (radio Rx, telephone Rx, media or logger playback) is present on the PA output.

## 6.11 Memo Recording

The AMU supports the ability to send Headset microphone audio to a Telephone Logger so that the Operator can record a voice memo. By default, the MEMO button is disabled.

When enabled, pressing and holding the MEMO button sends microphone audio from both headsets to the Telephone Logger output of the AMU rack interface. Memo recording only lasts for the duration of the button press. No other audio other than microphone audio and telephone Rx audio is present on the Telephone Logger output.

The memo function does not take priority over or disrupt the operation of the radio or telephone system.

- When the memo button is pressed during radio activity (or when radio activity starts during the memo recording), the memo function continues to operate and send microphone audio to the telephone logger, but does not affect the radio operation.
- When the memo button is pressed during telephone activity (or when telephone activity starts during the memo recording), the memo function continues to operate and send microphone audio to the telephone logger. Note that telephone activity causes microphone audio to be sent to the telephone logging port regardless of memo operation. Hence, the memo function does not affect this operation of telephone logging, nor affect the overall function of the telephone.

## 6.12 Activity Indicators

The AMU console panel will have LED activity indicators that reflect the transmit, receive and logging activity of the AMU.

### 6.12.1 Transmit LED (Green)

The AMU 'Tx' indicator that lights up any time a PTT or Alert tone is active and audio is being sent to the radio system. This LED responds to a PTT generated by either of the PTT/Alert buttons, the foot switches, or from the VPM. The 'Tx' indicator does not respond to any other transmit activity in the AMU where microphone audio is sent out, except for radio transmissions.

### 6.12.2 Receive LED (Yellow)

The AMU has an 'Rx' indicator that lights up any time a Call on Selected Channel output from the VPM is active and audio is received from the radio system. The 'Rx' indicator does not respond to any other audio source including the telephone system.

### 6.12.3 Logger LED (Red)

The AMU 'Logger Active' indicator that lights up whenever audio is being sent to either telephone or radio loggers.

## 6.13 Voice Logging Ports

The voice logging ports provide outputs to two voice recording loggers (Radio and telephone). Each logger output is provided on a separate RJ45 port. Each logger output port also contains a control signal (relay contact closure) for the corresponding logger. A logger playback input port is also provided, and supports balanced and unbalanced logger input connections. The unbalanced logger input supports connection to a PC sound card to allow for software based instant recall playback.

The radio logger output port contains one 600Ω balanced audio output and one contact closure logger control signal. The logger control signal closes when the logger port is active. The port is an RJ45 8-way modular connector and is only active when either a radio transmission is being sent (PTT or Alert tone active), or when radio receive activity is present. No Operator microphone audio is present at the logger unless a PTT is active.

The telephone logger output port contains one 600Ω balanced audio output and one contact closure logger control signal. The logger control signal closes when the logger port is active. The port is an 8-way modular connector and is only active when either the telephone is active ('off hook') or the Memo function is active. No Operator microphone audio is present at the logger unless the telephone or memo function is active.

Both logger outputs (and control signals) function if a headset is or is not connected to the AMU. It is possible for the Service User to configure the logger outputs ports & control signals such that the telephone or radio logging functions do not operate if no headsets are connected, instead requiring at least one headset be present for logging to take place.

The logger playback input port provides a 600Ω balanced audio input and two unbalanced inputs that is compatible with PC sound cards. The audio received from either of the unbalanced PC inputs are combined (mixed) and treated as one input by the AMU. The port is an RJ45 8 way modular connector.

The logger playback input audio is related to the selected Priority source. If in phone priority, phone off-hook activity will cause the logger input to temporarily mute then restore after 15 seconds. Likewise, if in radio priority, radio receive activity will cause the logger input to temporarily mute then restore after 15 seconds. Changing priority selection has no affect on an already muted logger playback, with the logger only restoring after the full 15 seconds (Service User programmable).

### Logging Playback Service Mode Options:

Logger playback temporary mute and auto-restore delay settings can have the following Service User values:

- Restore after 1 - 60 seconds
- Instant auto restore (after 0 seconds)

The logger playback input is always enabled. It is not be possible to be disabled, only temporarily muted during phone or radio activity. The logger playback signal goes to the speaker (when enabled), and always to the headset(s).

The Service User can also prevent Voice Logger inputs from being muted during radio or telephone calls.



## 6.14 AMU Telephone Audio

The AMU transmits and receives audio to/from the telephone network via the Operator's telephone headset port. The connection between the AMU and the Operator's headset port is fully isolated by the AMU in accordance with AS/NZS 60950. The AMU is NOT connected directly to a telephone line. For telephone calls to function properly through the AMU the Operator's telephone must also provide on hook and off hook signals by way of a normally open relay contact (closed when off hook) or a 3V3 active high signal.

There is no set standard for the RJ22 (also known as an RJ9) (4P4C) handset connector on a telephone. Some telephone manufacturers have mic (Tx) audio on the centre pair and the speaker (Rx) audio on the outer pair. Others reverse the Tx and Rx pairs and some reverse the polarity.

Therefore the cable between the AMU Telephone Headset Port and the Operator's telephone may vary but the AMU's Tx audio is always connected the telephone's mic input and the AMU's Rx audio is always connected to the telephone's speaker output.

### The Most Common Telephone Headset Port Pin-outs as used in the AM-5230H

Pin Number	Description	Level / Sensitivity
1	Speaker + (audio from telephone to AMU+)	Speaker +
2	Microphone – (audio from AMU to telephone – )	Microphone return
3	Microphone + (audio from AMU to telephone + )	5.6V bias
4	Speaker – (audio from telephone to AMU – )	Speaker return

The speaker polarity doesn't matter but the mic polarity must be correct, otherwise there will be no Tx audio.

## 6.14.1 3V Off-Hook Adaptor for Alcatel-Lucent Telephones

Alcatel-Lucent 8 Series IP Touch telephones do not provide on hook and off hook signals by way of a normally open relay contact (closed when off hook). Instead these phones provide a 3V3 active high signal when the phone is off hook.



When interfacing an Alcatel-Lucent 8 Series IP Touch telephone to the AMU, a special 3V Off Hook Adaptor is used, part number AD-5231:



To Alcatel  
Headset  
jack  
3.5mm  
stereo

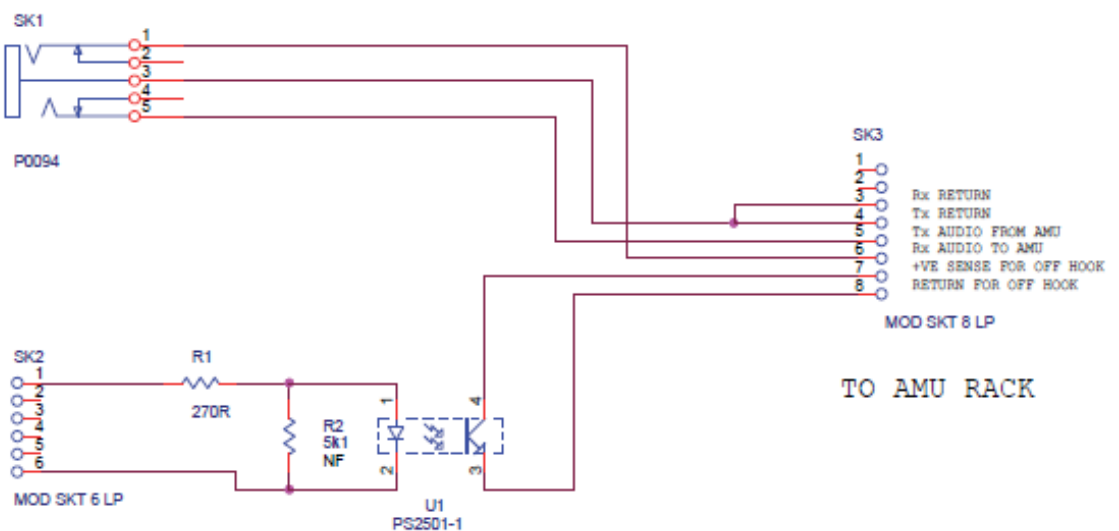

## 6.15 Light Tower Interface Box and ACD Busy

The Light Tower Interface Box allows the connection of an Operator light tower that indicates to the Supervisor what call(s) the Operators are currently on. It also provides a means of “busing out” the Operator’s position in the Telephone Automatic Call Distribution system so that they can only receive telephone calls when they are NOT on a radio call.

The interface also provides standard 3.5mm audio input jacks for PC sound card and TV headphone outputs.

Standard RJ45 UTP patch cables are used for connection to the AMU Rack Interface.

### IB-5355 Interface



### LIGHT TOWER



BLUE when an Operator is on a Radio call (for example)

# IB-5355 Interface Circuit Diagram

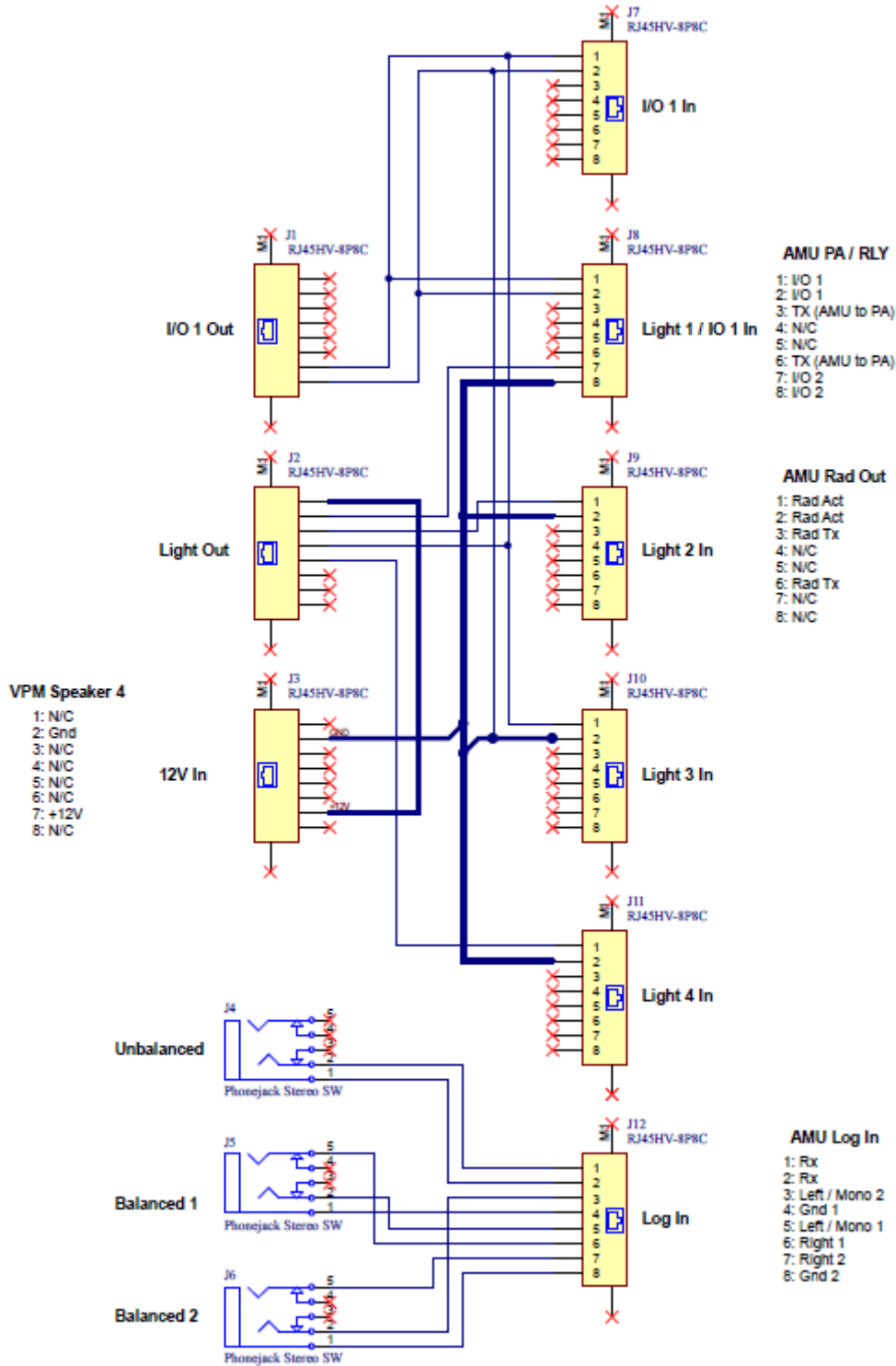

# 7. Warranty

The AM-5230Ms are original and brand new, manufactured by Design Two Thousand Pty Ltd to Quality Assurance Standard ISO 9001.

All equipment has a two-year warranty against defects in materials and workmanship from date of delivery.

The Warranty covers:

- Repair or replacement of faulty items returned to Design Two Thousand Pty Ltd.
- Return freight to Motorola.
- Help Desk telephone support.

The Warranty does not cover:

- On-site repair.
- Equipment subjected to misuse, accidental or lightning damage.
- Radio or Phone failure.

## **Failure within the Warranty Period**

- Faulty item(s) are to be returned to Design Two Thousand Pty Ltd.
- Design Two Thousand Pty Ltd will cover return transportation costs to Motorola.
- Turnaround time at factory is anticipated to be no longer than 48 hours plus transit.
- The consignor is to accept liability for loss or damage during transit.

## **Failure after the Warranty Period**

- Faulty item(s) are to be returned to Design Two Thousand Pty Ltd.
- Turnaround time at factory is anticipated to be no longer than 48 hours plus transit.
- Freight of equipment to and from Design Two Thousand Pty Ltd will be to Motorola's account.
- The consignor is to accept liability for loss or damage during transit.
- The cost of replacement depends on the component in need of replacement. This cost is not to exceed the price of a complete new unit.

## Help Desk

Design Two Thousand Pty Ltd offers a 24-hour, 7-day per week help desk number for Motorola assigned test officers to call. The Help Desk number is:

**03 9758 5933**

Any return calls are not limited by geographical location, subject to network availability.

The response time to a support request will generally be immediate but shall be no longer than 15 hours.

The Test Officer, as a minimum, shall:

- Be able to identify the product by model and serial number.
- Verify that the AM-5230M set appears to be properly installed.

After the warranty expires, Design Two Thousand Pty Ltd continues to offer a 24-hour, 7-day help desk number for Motorola test officers to call at nominal charges. The Help Desk number is:

**03 9758 5933**

Any return calls are not limited by geographical location, subject to network availability.

The response time to a support request will generally be immediate but shall be no longer than 15 hours.

The Test Officer, as a minimum, shall:

- Be able to identify the product by model and serial number.
- Verify that the AM-5230M set appears to be properly installed.

After the warranty has expired, Design 2000 will continue to support the product for at least ten years.

ACMA SUPPLIER CODE: N468  
ERAC RESPONSIBLE SUPPLIER NUMBER: E1287



# A1. AMU Terminal Configuration Commands

## A1.1 Connecting an ANSI Terminal to the AMU

The AMU is configured via RS-232 commands issued using an ANSI serial terminal configured as 8N1 (8 data bits, no parity, 1 stop bit).

The baud rate is 19,200. For a consistent interface experience the terminal should be configured to use a mono-spaced (fixed-width) font.

Many PC-based commercial, shareware and freeware terminal emulation packages are available. All should work with the AMU providing they can be configured with the above settings.

An example of a free terminal program for Windows is "Termite":

<http://www.compuphase.com/software/termite30.zip>

*"Termite 3.0 is copyrighted software that is free for personal and commercial use."*

Here is the Termite settings window configured to work with the AMU.

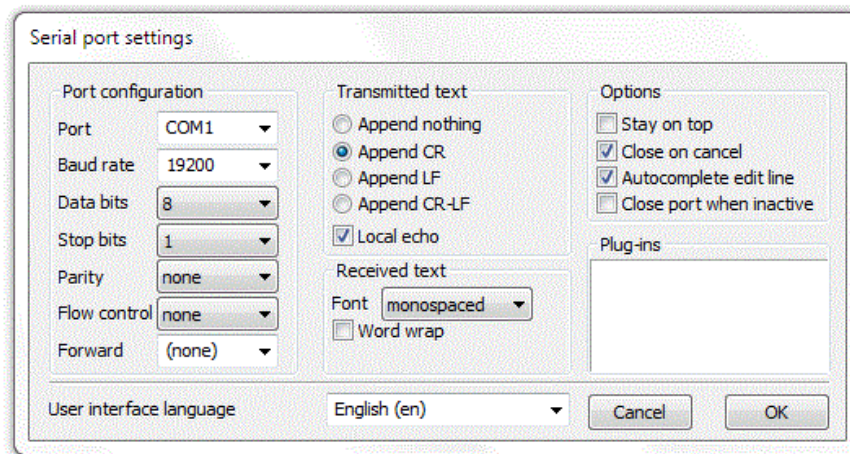

If your PC does not have a serial port, cheap USB-to-serial adaptors are readily available.

## A1.2 AMU to ANSI Terminal Interface Cable

To make changes to AMU settings, the ANSI terminal is connected to either one of the Footswitch jacks on the back of the AM-5230M Rack Interface.

A prewired RJ45 to DB9 adaptor is available for quick connection - part number **CA-5230/11**

RJ45 Pin Number	Description	DB9 female Pin Number	Conductor Colour
1			
2			
3			
4	Digital Ground OVD	5	Red
5	RS232 Rx data	3	Green
6	RS232 Tx data	2	Yellow
7			
8			

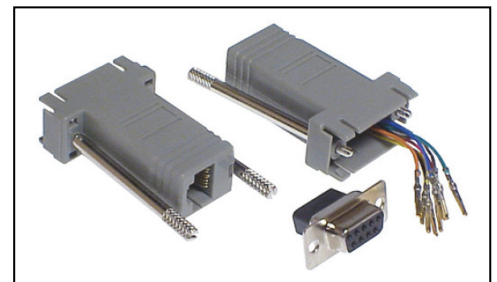

## A1.3 Audio Level Adjustments

Audio level setting sets the gain or attenuation applied to the input signal or to a tone signal generated by the AMU. These are relative settings and do not represent actual output levels in dBm which would require the entire MCC7500 system to be tested with reference tones at each input. Each increment in the 0 – 255 range represents a 2.5025mV RMS increase in gain. The defaults listed below are being used by existing MCC7500 customers. They provide an excellent starting point and when used with the MCC7500 system, these settings are unlikely to require much adjustment.

Telephone Sidetone level (including disabling it) <b>#TELSIDETONEVOL:n*</b> where n = 0 – 255 (0 = off)	(default = 0)
Radio Sidetone level (including disabling it) <b>#RADSIDETONEVOL:n*</b> where n = 0 – 255 (0 = off)	(default = 130)
Media Aux input 1 <b>#AUX1VOL:n*</b> where n = 0 – 255	(default = 128)
Media Aux input 2 <b>#AUX2VOL:n*</b> where n = 0 – 255	(default = 128)
Media Aux input 3 <b>#AUX3VOL:n*</b> where n = 0 – 255	(default = 128)
PA output <b>#PAVOL:n*</b> where n = 0 – 255	(default = 128)
Radio Logger Out <b>#RADLOGVOL:n*</b> where n = 0 – 255	(default = 150)
Telephone Logger Out <b>#TELLOGVOL:n*</b> where n = 0 – 255	(default = 255)
Logger input <b>#LOGRXVOL:n*</b> where n = 0 – 255	(default = 228)
Telephone Rx (from phone) <b>#TELRXVOL:n*</b> where n = 0 – 255	(default = 254)
Telephone Tx (to phone) <b>#TELTXVOL:n*</b> where n = 0 – 255	(default = 20)
Radio Rx (from VPM to AMU) <b>#RADRXVOL:n*</b> where n = 0 – 255	(default = 150)
Radio Tx (to VPM from AMU) <b>#RADTXVOL:n*</b> where n = 0 – 255	(default = 60)
Alert Tone (to Radio) <b>#ALERTVOL:n*</b> where n = 0 – 255	(default = 40)
PIP Tone (to Phone) <b>#PIPVOL:n*</b> where n = 0 – 255	(default = 3)
Headset Microphone pre-amp gain <b>#MICVOL:n*</b> where n = 0 – 255	(default = 150)
Maximum Console Speaker Volume <b>#MAXSPKRVOL:n*</b> where n = 0 – 10	(default = 7)



Minimum Headset Volume (allows you to prevent turning down headset Rx audio to silence)

**#HS1MINVOL:n\*** where n = 0 – 255 (default = 6)

**#HS2MINVOL:n\*** where n = 0 – 255 (default = 6)

## A1.4 Audio Level Meter (which audio sources are sent to the Level Meter)

Headset microphones

**#HSMICMTR:n\*** where n = 0 – 255 (default = 128)

Telephone receive audio

**#TELRXMTR:n\*** where n = 0 – 255 (default = 220)

Radio receive audio

**#RADRXMTR:n\*** where n = 0 – 255 (default = 220)

Media/aux audio

**#AUXMTR:n\*** where n = 0 – 255 (default = 128)

Logging playback

**#LOGRXMTR:n\*** where n = 0 – 255 (default = 128)

Mute the Meter display of Aux audio and Logger playback audio during auto mute cycles

**#AUTOMUTEMTR:n\*** where n = 0 or 1 (0 = disabled, 1 = enabled) (default = 1)

## A1.5 Media Aux. Audio Auto Mute Timer

How long before Aux Audio is restored after Radio or Telephone call

**#AUXMUTE:n\*** where n = 0 - 60 (0 = no auto restore) (default = 3) (seconds)

## A1.6 Feature Enable/Disable

Headset radio inhibit buttons for both headsets can be disabled

**#HS1RADMUTE:n\*** where n = 0 or 1 (0 = disabled, 1 = enabled) (default = 0)

**#HS2RADMUTE:n\*** where n = 0 or 1 (0 = disabled, 1 = enabled) (default = 0)

Aux 3 can be disabled

**#AUX3:n\*** where n = 0 or 1 (0 = disabled, 1 = enabled) (default = 1)

PIP tones can be disabled

**#PIPTONE:n\*** where n = 0 or 1 (0 = disabled, 1 = enabled) (default = 0)

Operator Assist feature can be disabled

**#PA:n\*** where n = 0, 1 or 2 (0 = disabled, 1 = momentary, 2 = latching) (default = 2)

Memo feature can be disabled

**#MEMO:n\*** where n = 0 or 1 (0 = disabled, 1 = enabled) (default = 1)

VOX can be used instead of VPM Channel Activity output to detect Radio Rx

**#VOX:n\*** where n = 0 or 1 (0 = disabled, 1 = enabled) (default = 1)  
(when enabled both the VOX and Channel Activity relay work)

Set VOX sensitivity:

**#VOXSENS:n\*** where n = 0 to 20 (0 = most sensitive, 20 = least sensitive) (default = 0)

Set VOX hang time in 500ms steps:

**#VOXHANG:n\*** where n = 0 to 10 (0 = no hang time, 1 = 500ms, 2 = 1000ms, 4 = 2000ms,  
5 = 2500ms, 10 = 5000ms) (default = 4 (2000ms, 2 sec))

Enable or Disable the Alert Tone

**#ALERT:n\*** where n = 0 or 1 (0 = disabled, 1 = enabled) (default = 1)

Radio Rx audio Overload (OL) detect. This Feature is used as a peak limiter to automatically reduce loud radio audio sent to the Operator headsets:

**#OLRADETECT:n\*** where n = 0 or 1 (0 = disabled, 1 = enabled) (default = 1)

Set Overload detect sensitivity:

**#OLRADESENS:n\*** where n = 0 - 255 (default = 200) (The smaller the number the sooner it detects overload)

Set how much the AMU ducks (reduces) the overloaded Radio Rx audio to the headsets:

**#OLRADDUCKVOL:n\*** where n = 0 - 255 (default = 80)

Set how long the ducking persists:

**#OLRADDUCKHANG:n\*** where n = 0 to 10 (0 = no hang time, 1 = 100ms, 2 = 200ms, 3 = 300ms, 4 = 400ms, 5 = 500ms, 10 = 1000ms) (default = 5 (500ms, 0.5 sec))

The AMU can detect when a headset is plugged into the headset connector box to change the colour of the Console headset buttons and to switch audio paths. Detect when headset is plugged in by checking the Headset mic voltage every two seconds:

**#HSDetect:n\*** where n = 0 or 1 (default = 1, ON)

Transmit Voice Logger Playback Audio to the AMU Console Speaker:

**#LOGTOSPKR:n\*** where n = 0 or 1 (default = 1, ON / ACTESA default = 0, OFF)

## A1.7 Logging Playback Mute Timer

How long before Logger Audio is restored after Radio or Telephone call

**#LOGMUTE:n\*** where n = 0 - 60 (0 = instant restore) (default = 15) (seconds)

## A1.8 Priority Control Behavior

How the Phone/Radio Priority Control buttons operate. There is the “both selected” state and the “none selected” state that can be independently enabled.

Both Priorities selected state:

**#PRCNTRL1:n\*** where n = 0, 1 or 2  
0 = both priorities can be turned ON, radio priority when both ON  
1 = both priorities can be turned ON, first in/first out priority when both are ON (Default)  
2 = disable ability to turn ON both priorities

No Priority selected state:

**#PRCNTRL0:n\*** where n = 0, 1 or 2  
0 = both priorities can be turned OFF, radio priority when both OFF  
1 = both priorities can be turned OFF, first in/first out priority when both are OFF  
2 = disable ability to turn OFF both priorities  
3 = both can be turned OFF, no ducking of phone or radio audio (Default)

How much the Telephone Rx level drops when “ducked”

**#PRTELDUCKVOL:n\*** where n = 0 – 255 (0 = mute) (default = 80)

How much the Radio Rx level drops when “ducked”

**#PRRADDUCKVOL:n\*** where n = 0 – 255 (0 = mute) (default = 20)

How much the Telephone Tx level drops during Radio Rx with both priorities selected (to reduce Radio Rx headset crosstalk sent to remote telephone)

**#TELTXDUCKVOL:n\*** where n = 0 – 255 (0 = mute) (default = 20)

## A1.8.1 Alternate Priority Control Functionality

- #TELPRCNTRLALT:n\*** where n = 0 ,1 or 2  
0 = normal Telephone priority as per A1.8 (Default)  
1 = no Radio Rx audio in headset(s) when PHONE Priority is selected.  
(Radio Rx does not mute Aux. inputs)  
(Radio Rx does not mute Logger playback)  
(Rx LED still operates)  
(Radio Rx audio still goes to meter, speaker and logger)  
2 = as per state 1 but no Radio Logging when PHONE Priority is selected.
- #RADPRCNTRLALT:n\*** where n = 0 or 1  
0 = normal Radio priority as per A1.8 (Default)  
1 = no Phone Rx audio in headset(s) when RADIO Priority is selected.  
(Phone off hook mutes Aux. inputs)  
(Phone off hook mutes Logger playback)  
(Phone Rx audio still goes to meter and logger)

## A1.9 General Features

Indicator brightness/dimming can be changed

- #LEDBRIGHT:n\*** where n = 0 – 255 (default = 1)

Telephone and Radio Logger control signals and audio can be changed to only function with a headset connected, or set to always function

- #LOGCNTRL:n\*** where n = 0 or 1 (0 = LOG Relays and Audio operates only when headset(s) is connected)  
(1 = LOG Relays and Audio always operates regardless of whether headset(s) is connected or disconnected)  
(default = 1)

The AMU can tell the VPM when the headset connector box is plugged in so that the VPM can switch audio paths. The VPM headset connected signal can be programmed to only be active (relay closed) when a connector box is connected, or always be active

- #HSDISC:n\*** where n = 0 or 1 (0 = H/SET Relay closed only when headset is connected) (Default)  
(1 = H/SET Relay always closed when AMU powered up)

An operator can talk to a Supervisor via their headsets for training purposes. The headset receive volume of the other headset transmit audio is adjustable from 0 to 255.

- #HSHATVOL:n\*** where n = 0 – 255 (Default = 0)

Any flashing/pulsating or otherwise “not solid” indicators have the option to be set to a solid light

- #LEDFLASH:n\*** where n = 0 or 1 (0 = no flash, 1 = flash)  
(default = 0)

Customer Mode enables you to automatically load the features required by different customers

- #CUSTOMER:n\*** where n = 0 or 1 (0 = NSWPF)  
(1 = ACTESA – defaults, ability to mute headset mic, no Alert, no Logger audio to speaker, max. speaker volume set to 6)  
(2 = WAPOL – All logger audio sent to TEL OUT Logger port)  
(3 = SAGRN – All logger audio sent to TEL OUT Logger port)  
(3 is Default)  
(4 = NSWRFSS defaults)

Firmware Version Number

- #VERSION\*** The installed firmware version is displayed eg. V1.51

## A1.10 AMU Settings Dump

All AMU Settings may be retrieved for review and also copied to another AMU.

**#GETSET\*** Issuing a **#GETSET\*** command displays a listing to the terminal of all current settings and their values. The list is presented in a form that can be easily copied and pasted to another AMU terminal to quickly duplicate the configuration from one unit to another. Here is an example only (SAGRN) as at 20180710:

```
-----  
> Current settings (refer to handbook for details)  
-----
```

```
#TELSIDETONEVOL:0*  
#RADSIDETONEVOL:130*  
#AUX1VOL:128*  
#AUX2VOL:128*  
#AUX3VOL:128*  
#HS1MINVOL:6*  
#HS2MINVOL:6*  
#PAVOL:128*  
#RADLOGVOL:150*  
#TELLOGVOL:255*  
#LOGRXVOL:228*  
#TELRXVOL:254*  
#TELTXXVOL:20*  
#RADRXVOL:150*  
#RADTXVOL:60*  
#ALERTVOL:40*  
#PIPVOL:3*  
#PRTELDUCKVOL:80*  
#PRRADDUCKVOL:20*  
#TELTXXDUCKVOL:20*  
#MICVOL:150*  
#HSCHATVOL:0*  
#MAXSPKRVOL:7*  
#HS1RADMUTE:0*  
#HS2RADMUTE:0*  
#AUX3:1*  
#PIPTONE:0*  
#ALERT:1*  
#PA:2*  
#MEMO:1*  
#LEDBRIGHT:1*  
#LOGCNTRL:1*  
#HSDISC:0*  
#HSDetect:1*  
#LEDFLASH:0*  
#AUXMUTE:3*  
#LOGMUTE:15*  
#PRCNTRL1:1*  
#PRCNTRL0:3*  
#TELPRCNTRLALT:0*  
#RADPRCNTRLALT:0*  
#AUTOMUTEMTR:1*  
#LOGTOSPKR:1*  
#LOGPLAYREC:0*  
#HSMICMTR:128*  
#HSMICMTR:128*  
#TELRXMTR:220*  
#RADRXMTR:220*  
#AUXMTR:128*  
#LOGRXMTR:128*  
#VOX:1*  
#VOXSENS:1*  
#VOXHANG:4*  
#OLRADDETECT:1*  
#OLRADSENS:200*  
#OLRADDUCKVOL:80*  
#OLRADDUCKHANG:5*  
#CUSTOMER:3*  
-----
```

## A1.11 AMU Service Mode Input Errors

An example of a command entered correctly:

```
#LEDFLASH:1*  
[OK: LEDFLASH SET TO 1]
```

An example of a command entered with a parameter outside of the allowable range:

```
#LEDFLASH:2*  
[ERROR: LEDFLASH ALLOWED RANGE IS 0 TO 1]
```

An example of a command entered with missing parameters:

```
#LEDFLASH*  
[ERROR: LEDFLASH NEEDS 1 PARAMETER(S)]
```

An example of a command typed incorrectly:

```
#FLASHLED:1*  
[ERROR: 'FLASHLED' IS UNKNOWN]
```

## A1.12 AMU Level Meter Mode

- The level meter normally operates in 'dot' mode but it is possible to enable 'bar graph' mode by changing a hardware link LK2 on the Console PBA.

## A1.13 AMU Settings back to Default

All AMU Settings may be set back to default.

```
#DEFAULT* Issuing a #DEFAULT* command sets all settings to the default values. "OK: ALL  
SETTINGS RESTORED TO DEFAULTS" is returned.
```

## A1.14 AMU Soft Reboot

After making changes to any settings it is recommended to perform a soft reboot (also know as a warm boot) to initialize the system.

```
#RESET* Issuing a #RESET* command performs a soft reboot and initializes any changes made to  
the settings. Also the firmware version will be displayed.
```

# A2. Firmware Update Procedure

## A2.1 In-Circuit Firmware Programmer

A melabs In-Circuit Firmware Programmer AM-5230/12 is available for performing firmware updates in the AMU Console and the Rack Interface.

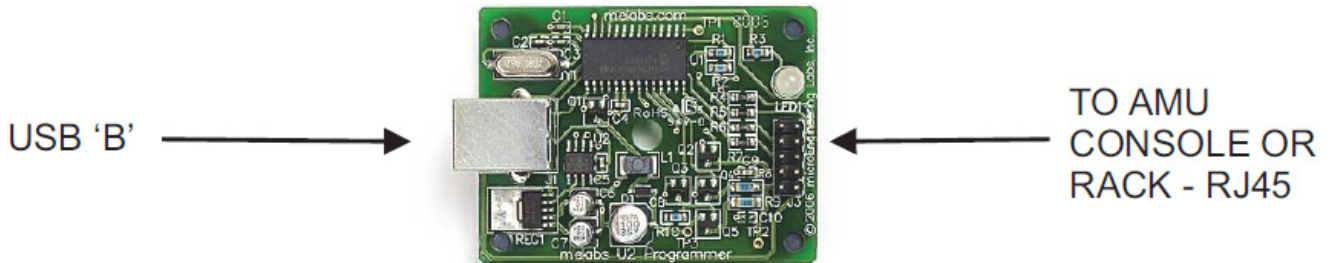

It is provided in a jiffy box labeled AM-5230/12 prewired with a USB cable for a Laptop computer and an RJ45 cable for the AMU Console or Rack Interface.

The In-Circuit Firmware Programmer is plugged into the Console Remote PTT/Alert Switch jack for updating the Console firmware. The connectivity is:

### Remote PTT/Alert Switch 8P8C RJ45 jack to melabs U2 In-Circuit Firmware Programmer

RJ45 Pin Number	Description	Level / Sensitivity	10 Pin Prog. Header	Conductor Colour T568A
1				
2	Firmware update voltage	Programming Voltage (VPP) (8V)	2	Green
3				
4	Digital Ground	0VD	10	Blue
5				
6				
7	Firmware update clock	Programming Clock (PGC)	8	White/Brown
8	Firmware update data	Programming Data (PGD)	6	Brown



The In-Circuit Firmware Programmer is plugged into either one of the Rack Interface Footswitch jacks for updating the Rack Interface firmware. The connectivity is:

### Footswitch 8P8C RJ45 jack to melabs U2 In-Circuit Firmware Programmer

RJ45 Pin Number	Description	Level / Sensitivity	10 Pin Prog. Header	Conductor Colour T568A
1				
2	Firmware update voltage	Programming Voltage (VPP) (8V)	2	Green
3				
4	Digital Ground	0VD	10	Blue
5				
6				
7	Firmware update clock	Programming Clock (PGC)	8	White/Brown
8	Firmware update data	Programming Data (PGD)	6	Brown

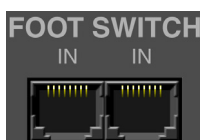

## A2.2 Updating the Firmware

### A2.2.1 Installing the Programmer Software

The programmer software is on the included disk labeled "melabs Programmer". It must be installed on a laptop computer before use.

To install the software, execute SETUP.EXE on the disk and follow the setup instructions presented. Accept all defaults, including the suggested installation directory.

The programmer software contains many options and settings. Design 2000 has created a settings file used by the programmer software with all required configuration parameters pre-set to make installation easier. This file is called "meProg.ini" and can be downloaded here: <http://www.design2000.com.au/support/motorola/meProg.zip>

Extract "meProg.ini" from the ZIP file into the programmer software installation directory on your PC (eg. "C:\Program Files (x86)\melabs Programmer") overwriting any existing file.

Now connect the programmer hardware to the PC using an available USB port. If asked, tell Windows to automatically search for the correct hardware driver.

### A2.2.2 Uploading New Firmware to the Rack or Console

Once the hardware is successfully installed, run the programmer software by double-clicking the "melabs Programmer" shortcut on your Windows desktop.

Then load the firmware HEX file into the programmer by selecting "Open..." from the "File" drop-down menu at the top of the window. Navigate to the location on your hard drive containing the latest "rack.hex" or "console.hex" file and click the "Open" button.

NOTE: The latest firmware for both the AMU Rack and Console is always available here: <http://www.design2000.com.au/support/motorola/rack.zip>  
<http://www.design2000.com.au/support/motorola/console.zip>

Make sure the programmer is connected to the AMU Rack or Console using the supplied cable plugged into the Footswitch or Remote PTT/Alert Switch RJ-45 connector. The AMU Rack uses a PIC 18LF8722 processor (default) and the AMU Console uses a PIC 18LF4620 processor which can be selected from the drop-down list shown here:

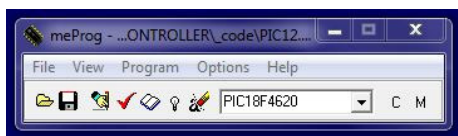

Note that the "L" code is missing in the drop down list. This stands for the "Low" power consumption version of the micro. It programs the same as the "non L" version.

After selecting the right micro, select "Program" from the "Program" drop-down menu. A progress bar will show the status of the operation. If no errors are displayed then the AMU Rack hardware or Console hardware has been successfully updated with new firmware and you can close the programmer software window.

If you encounter errors or require technical support, please contact Design 2000's Engineering Project Manager ([mike@design2000.com.au](mailto:mike@design2000.com.au)).



# A3. Specifications

Console Enclosure	3U high (132 mm), 112 mm high on 45° stand, 425 mm wide, 19" rack mount brackets optional (483 mm O.D.), 35 mm deep plus controls
Rack Enclosure	1U high (44 mm), 19" rack mount (483 mm O.D.), 250 mm deep plus connectors
Finish	Dulux Mannex Racking Grey 901-84225 powder coat
Screen Printing	PANTONE Cool Gray C2
Power Requirement	12V d.c. nominal, RJ45 pin 2 GND, pin 7 +12V
Power Consumption	300 mA @ 12V
Initial Start Up Current	750 mA for 90 ms @ 12V
Operating Temperature Range	-10 → 60 ° C
Storage Temperature Range	-20 → 80 ° C ambient
Humidity, Storage and Operating	To 98% non condensing
Mean Time Between Failure:	> 20 years
Processors	PIC 18LF4620 (Console) PIC 18LF8722 (Rack)
Digital Potentiometers	MCP4361 series
Firmware Storage Medium	Non-volatile
Audio Interfaces	600 Ohm balanced, transformer isolated, mono or stereo mixed to mono
Line Input level	-35 → 0 dBm (-10 dBm nom.)
Mic Input level	-34 dBm nom.
Output level	-35 → -3 max. dBm programmable (-10 dBm nom.) Peak limiting at -3dBm (programmable), attack time < 1 ms Instantaneous clamping at 3 dBm (3.1V peak to peak)
Frequency range	300 Hz → 5 kHz.
Channel Activity detect	Voltage free contact closure in
PTT	Voltage free contact closure out
Voice Logger Activation	Voltage free contact closure out
Strobe & PA Activation	Voltage free contact closure out
Telephone Interface	4 wire isolated to AS/NZS 60950
Output (Tx) d.c. Impedance	240 kOhms
Input (Rx) d.c. Impedance	4k7 Ohms
In-band Signalling	
Alert Tone	Alternating 800/1500 Hz sine wave, -15 dBm nom, 250ms each tone
PIP Tone	1.4kHz sine wave, -23 dBm nom, 425 ms every 15 s
Push Buttons	SHANPU CO., LTD. SPG2NB"X"CBSC SPG2
PTT and Alert Buttons	As above
Volume Knobs	H6514BK 18 tooth splined shaft, 23mm dia. x 17mm high
Displays	Rectangular Z078"X" 5mm x 2mm LEDs
RS232 Port	19,200 baud, N81 format
ACMA Supplier Code Number	N468
ERAC Responsible Supplier No.	E1287
Warranty	Two years
Part Numbers	
AM-52030CM	Console
AM-5230RM	Rack Interface
AM-5230H	Headset Connector Box
AM-5230S	Remote PTT/Alert Switch Assembly
AD-5231	3V Off-Hook Adaptor for Alcatel-Lucent Telephones
IB-5355	Light Tower Interface Box

ACMA SUPPLIER CODE: N468  
ERAC RESPONSIBLE SUPPLIER N<sup>o</sup>.: E1287



# A4. AMU Circuit Diagrams

1. Console
2. Rack
3. Headset Connector Box
4. Light Tower Interface Box

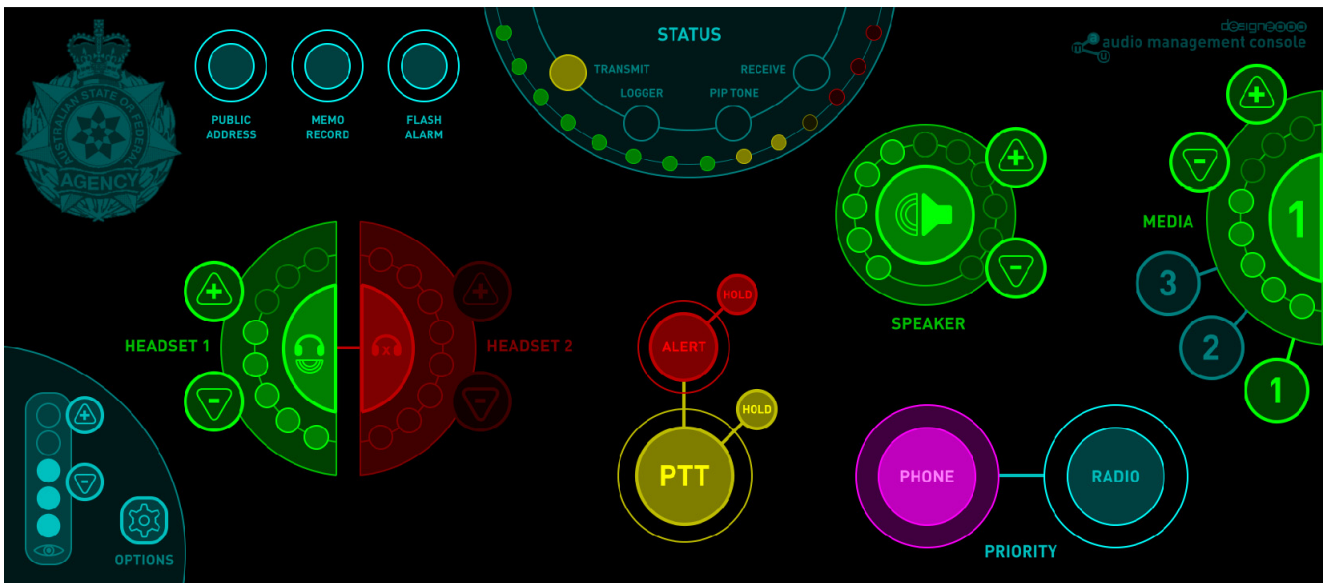

The AMU-5230M is a Fly-by-wire (FBW) design. Any button or potentiometer can be programmed to control any function. It is a digital matrix switch where any audio input can be programmed to appear at any output. Audio sources are not digitized. They are left in analogue form, amplified or attenuated by digital potentiometers via low noise, low distortion operational amplifiers to maintain the purest possible audio. In addition, audio inputs and outputs are transformer isolated that provide the required electrical isolation and prevention of ground loop hum.

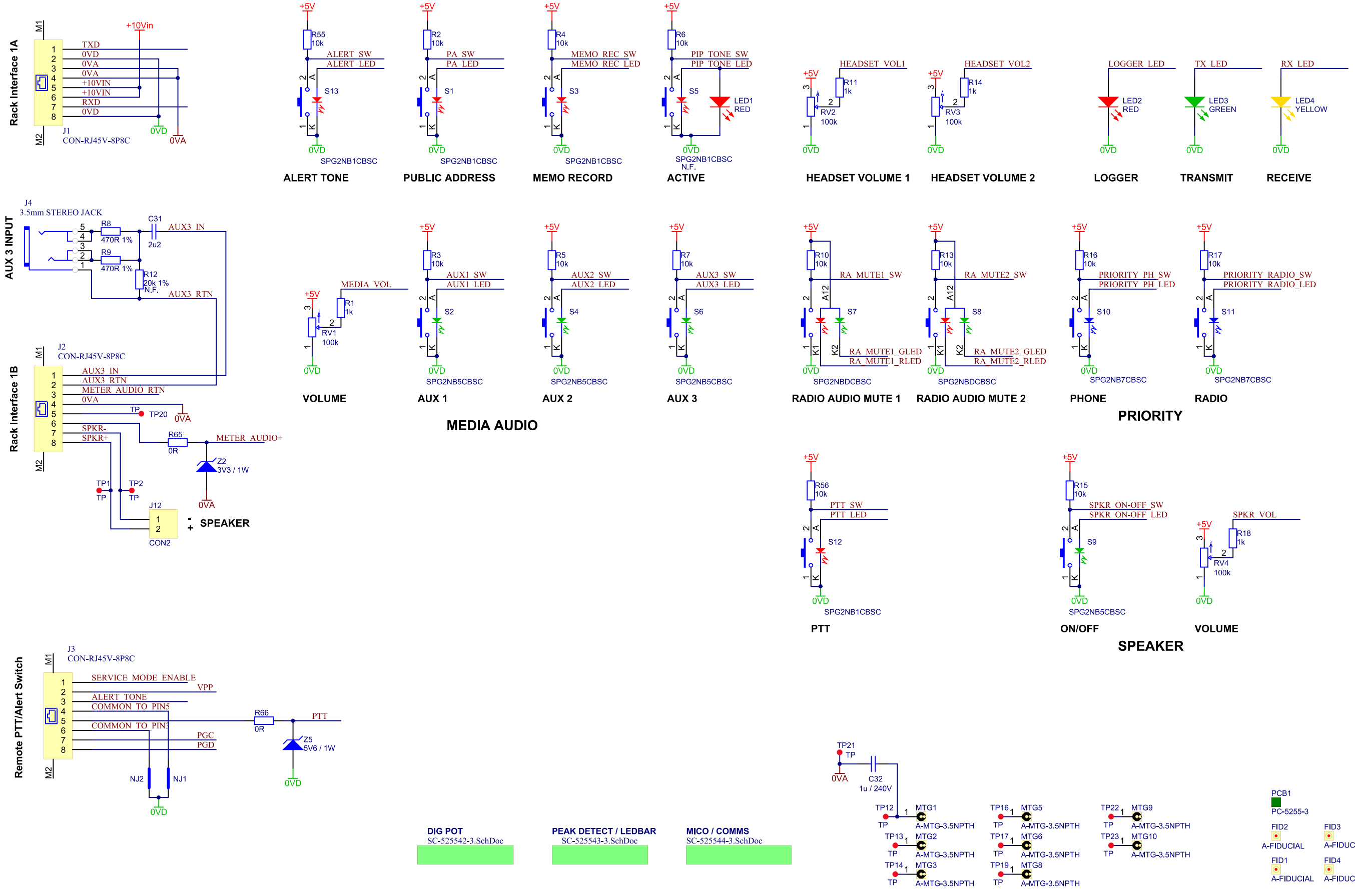

LOAD OPTION: Not Fitted = N.F.

ISSUE	CHANGE DETAILS	POSITION	ECO No.	DRAWN	DATE	<b>DESIGN TWO THOUSAND PTY LTD</b> 9-11 Rose Street P.O. Box 7020 Upper Ferntree Gully Victoria Australia ABN 45 005 014 639	TITLE:		
1	Mods for production release			ICT	22MAR2013		<b>AMU CONSOLE</b>		
3	Mods for production release			ICT	08MAR2017		DWG No. <b>SC-525541</b>	REV <b>3</b>	SHEET 1 OF 4
							DATE 8/03/2017	CHKD	
							FILE SC-525541-3.SchDoc		

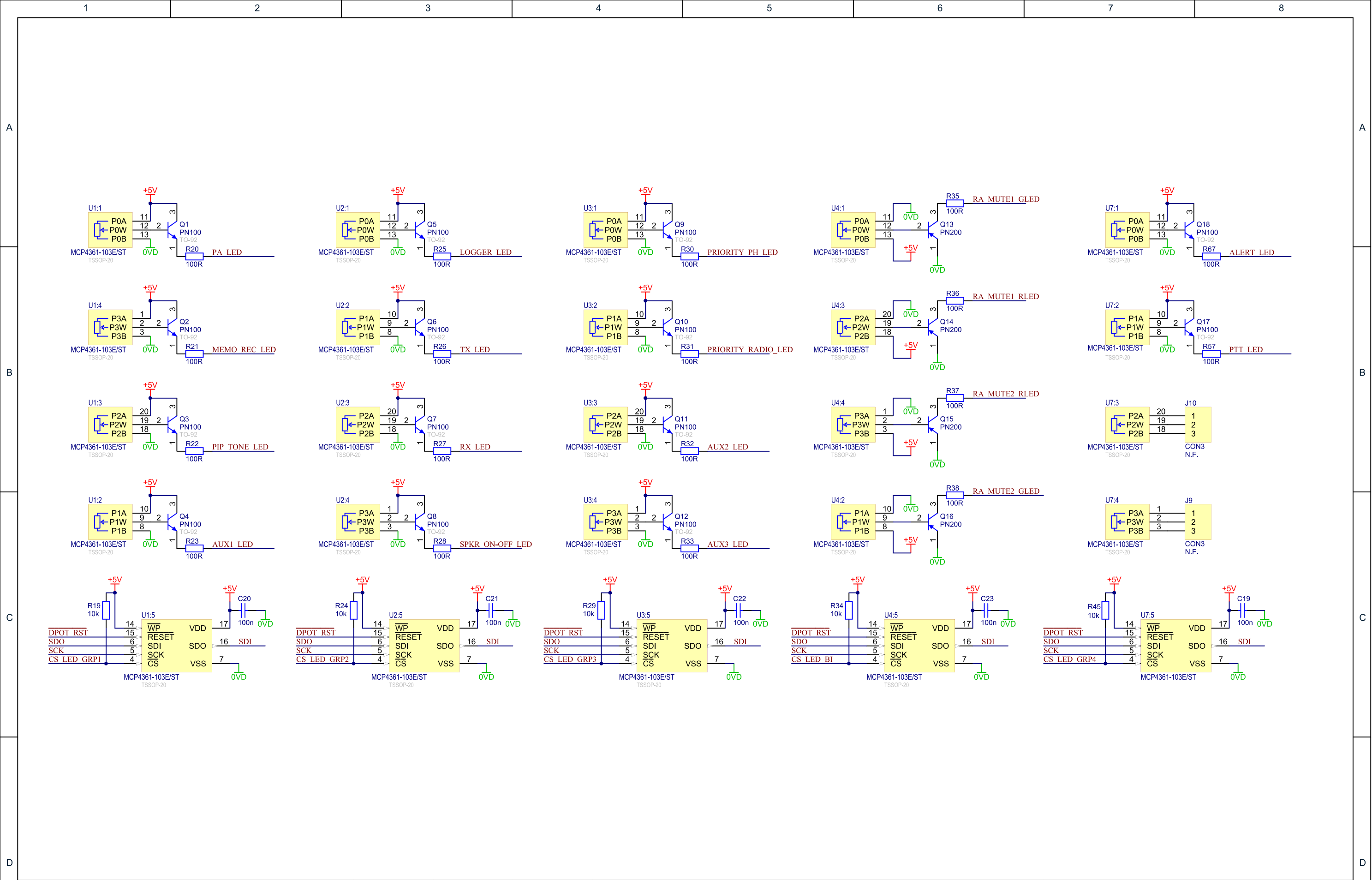

ISSUE	CHANGE DETAILS	POSITION	ECO No.	DRAWN	DATE	<b>DESIGN TWO THOUSAND PTY LTD</b> 9-11 Rose Street P.O. Box 7020 Upper Ferntree Gully Victoria Australia ABN 45 005 014 639	TITLE: <b>AMU CONSOLE</b>		
1	Mods for production release			ICT	22MAR2013		DWG No. <b>SC-525542</b>	REV <b>3</b>	SHEET 2 OF 4
3	Mods for production release			ICT	08MAR2017		DATE 8/03/2017	CHKD	
							FILE SC-525542-3.SchDoc		

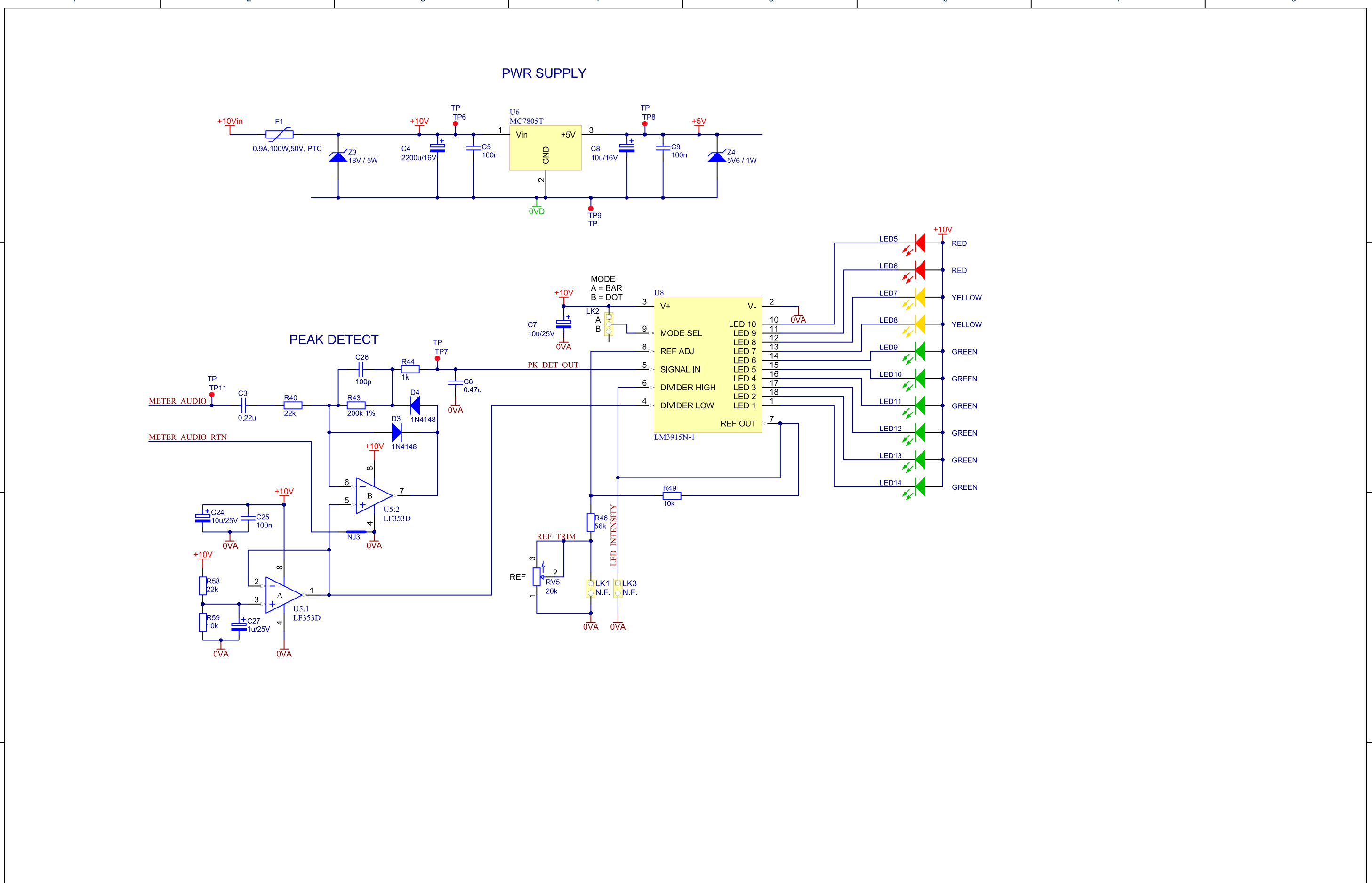

ISSUE	CHANGE DETAILS	POSITION	ECO No.	DRAWN	DATE	<b>DESIGN TWO THOUSAND PTY LTD</b> 9-11 Rose Street P.O. Box 7020 Upper Ferntree Gully Victoria Australia ABN 45 005 014 639	TITLE: <b>AMU CONSOLE</b>		
1	Mods for production release			ICT	22MAR2013		DWG No. <b>SC-525543</b>	REV <b>3</b>	SHEET 3 OF 4
3	Mods for production release			ICT	08MAR2017		DATE 8/03/2017	CHKD	
							FILE SC-525543-3.SchDoc		



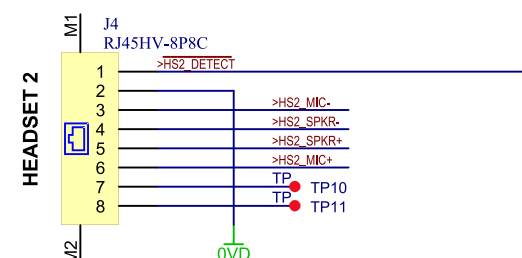
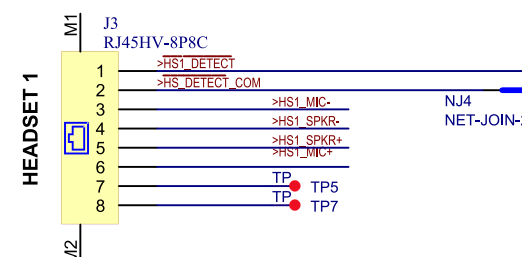
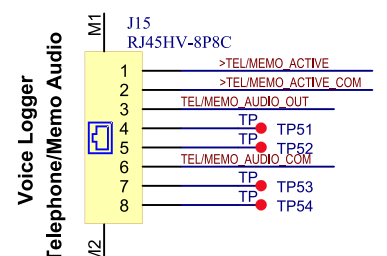
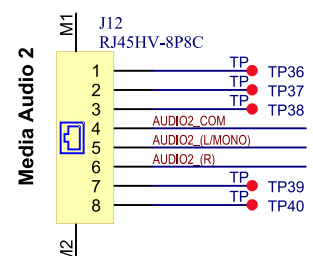
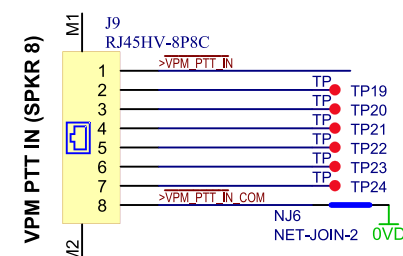
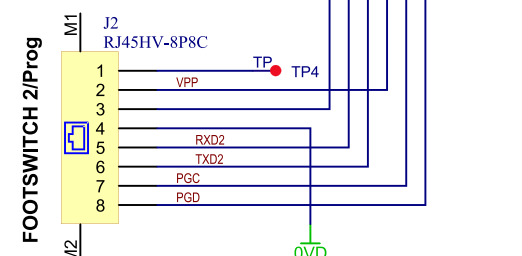
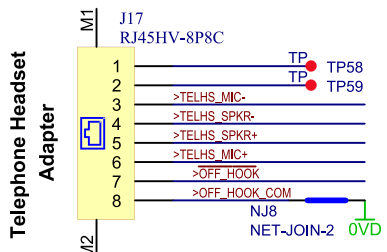
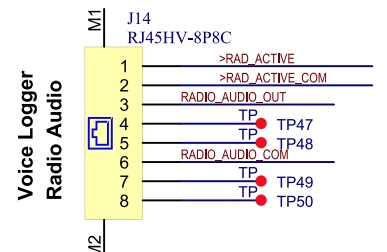
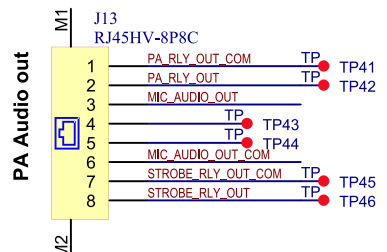
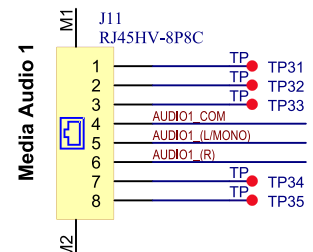
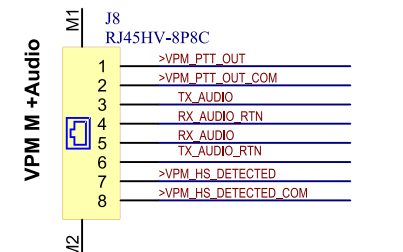
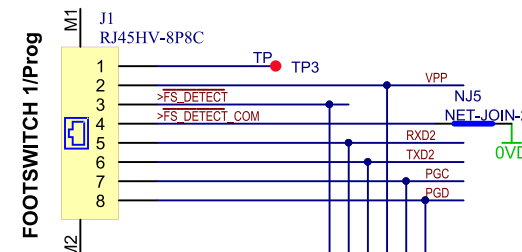

**CONTACT CLOSURE IO**  
SC-525842-3-CONTACT CLOSURE IO.SchDoc

**MIC IN**  
SC-525843-3-MIC IN.SchDoc

**TONE IN**  
SC-525844-3-TONE IN.SchDoc

**STEREO-MONO AUDIO IN**  
SC-525845-3-STEREO-MONO AUDIO IN.SchDoc

**DIGPOT - MIXER**  
SC-525849-3-DIGPOT.SchDoc

**PROCESSOR - COMMS - PSU**  
SC-5258410-3-PROCESSOR.SchDoc

**BALANCED OUT**  
SC-525846-3-BAL-OUT.SchDoc

**HEADPHONE-OUT**  
SC-525847-3-HEADPHONE-OUT.SchDoc

**SPKR-OUT**  
SC-525848-3-SPKR-OUT.SchDoc

**INPUTS**

**MIXING & CONTROL**

**OUTPUTS**

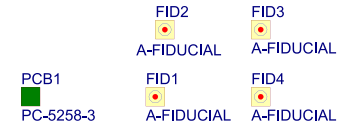
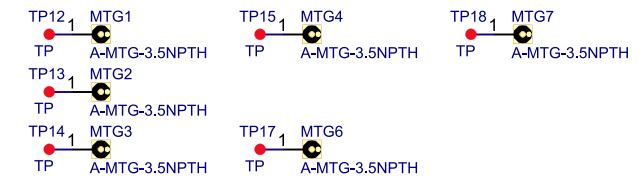
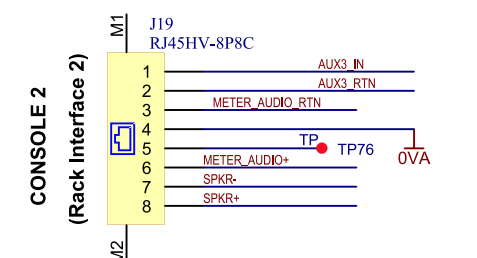
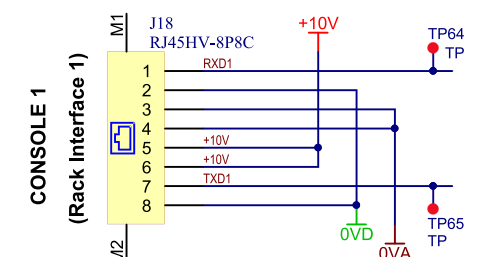

LOAD OPTION: Not Fitted = N.F.

ISSUE	CHANGE DETAILS	POSITION	ECO No.	DRAWN	DATE	<b>DESIGN TWO THOUSAND PTY LTD</b> 9-11 Rose Street P.O. Box 7020 Upper Ferntree Gully Victoria Australia ABN 45 005 014 639	TITLE:		
2	Mods for production release			ICT	25MAR2013		<b>AMU RACK I/F - Connector I/O</b>		
3	Mods for production release			ICT	05APR2017		DWG No. <b>SC-525841</b>	REV <b>3</b>	SHEET <b>1</b> OF <b>10</b>
							DATE 5/04/2017	CHKD	
							FILE SC-525841-3-CONN IO.SchDoc		

**FOOTSWITCH**

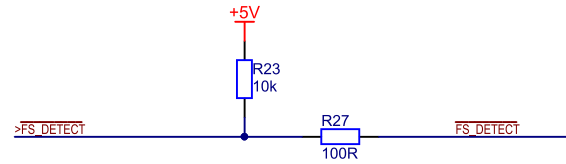

**HEADSET 1**

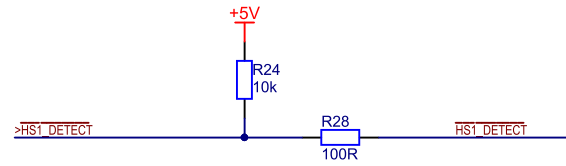

**HEADSET 2**

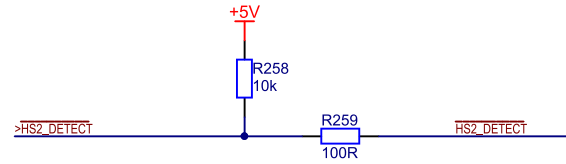

**VPM PTT IN (SPKR 8)**

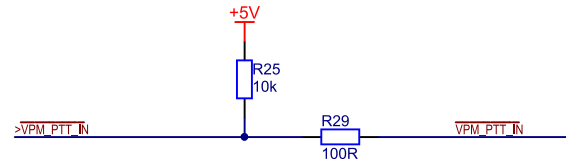

**VPM COSC (SPKR 7)**

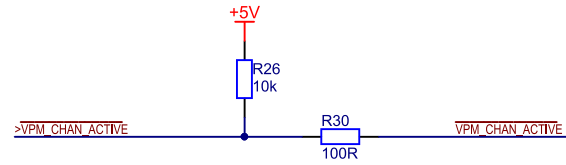

**Telephone Headset Adapter**

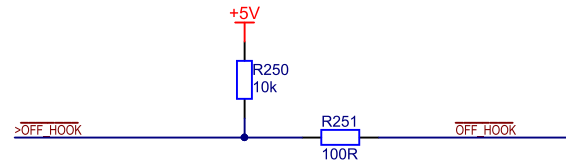

CONTACT CLOSURE IN

**VPM M +Audio**

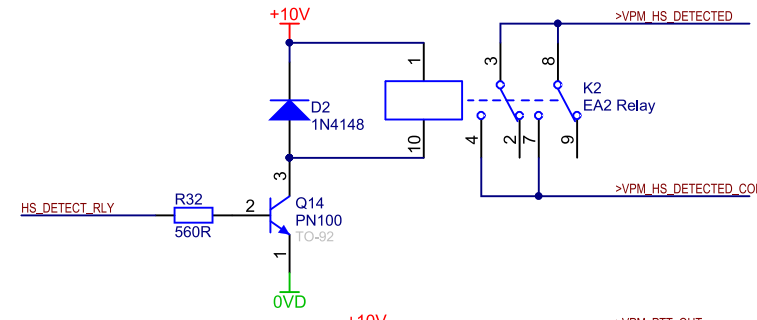

**VPM M +Audio**

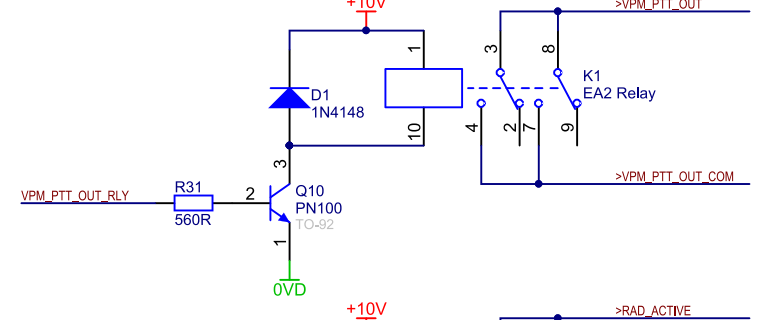

**Voice Logger  
Radio Audio**

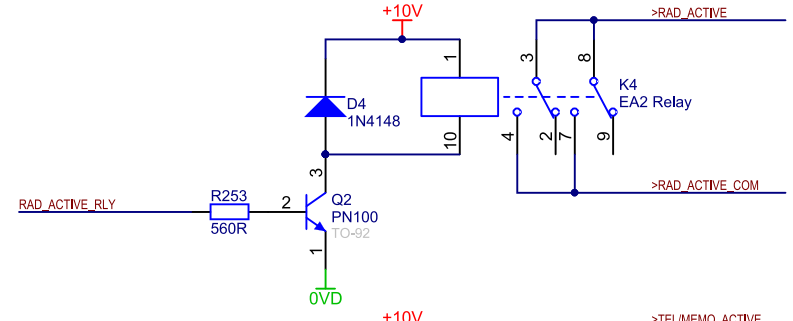

**Voice Logger  
Telephone/Memo Audio**

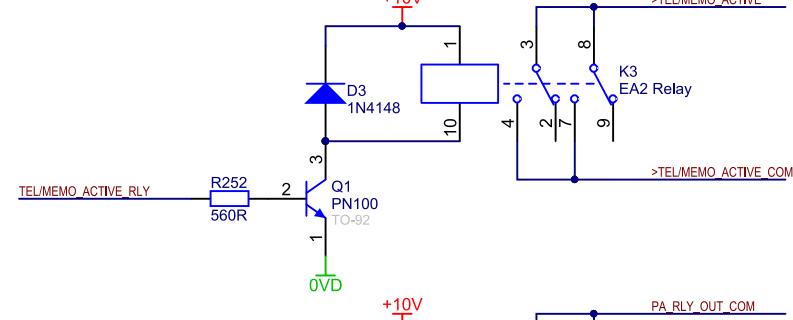

**PA Audio out  
PA**

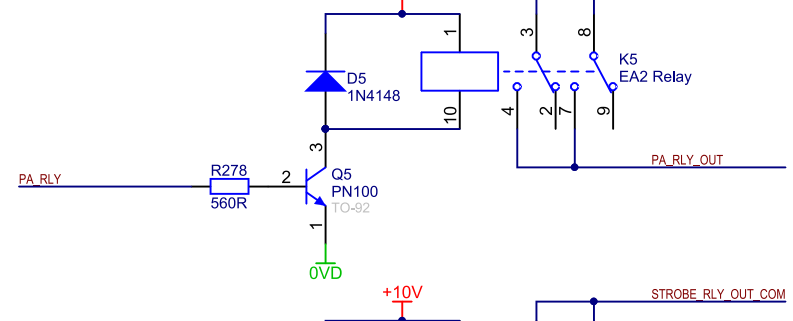

**PA Audio out  
Strobe**

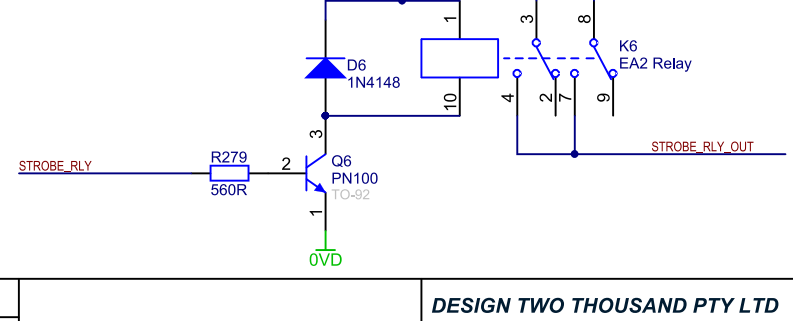

CONTACT CLOSURE OUT

ISSUE	CHANGE DETAILS	POSITION	ECO No.	DRAWN	DATE
2	Mods for production release			ICT	25MAR2013
3	Mods for production release			ICT	05APR2017

**DESIGN TWO THOUSAND PTY LTD**  
 9-11 Rose Street  
 P.O. Box 7020  
 Upper Ferntree Gully  
 Victoria Australia  
 ABN 45 005 014 639

TITLE: <b>AMU RACK I/F - Contact Closure I/O</b>		
DWG No. <b>SC-525842</b>	REV <b>3</b>	SHEET <b>2</b> OF <b>10</b>
DATE <b>5/04/2017</b>	CHKD	
FILE <b>SC-525842-3-CONTACT CLOSURE IO.SchDoc</b>		



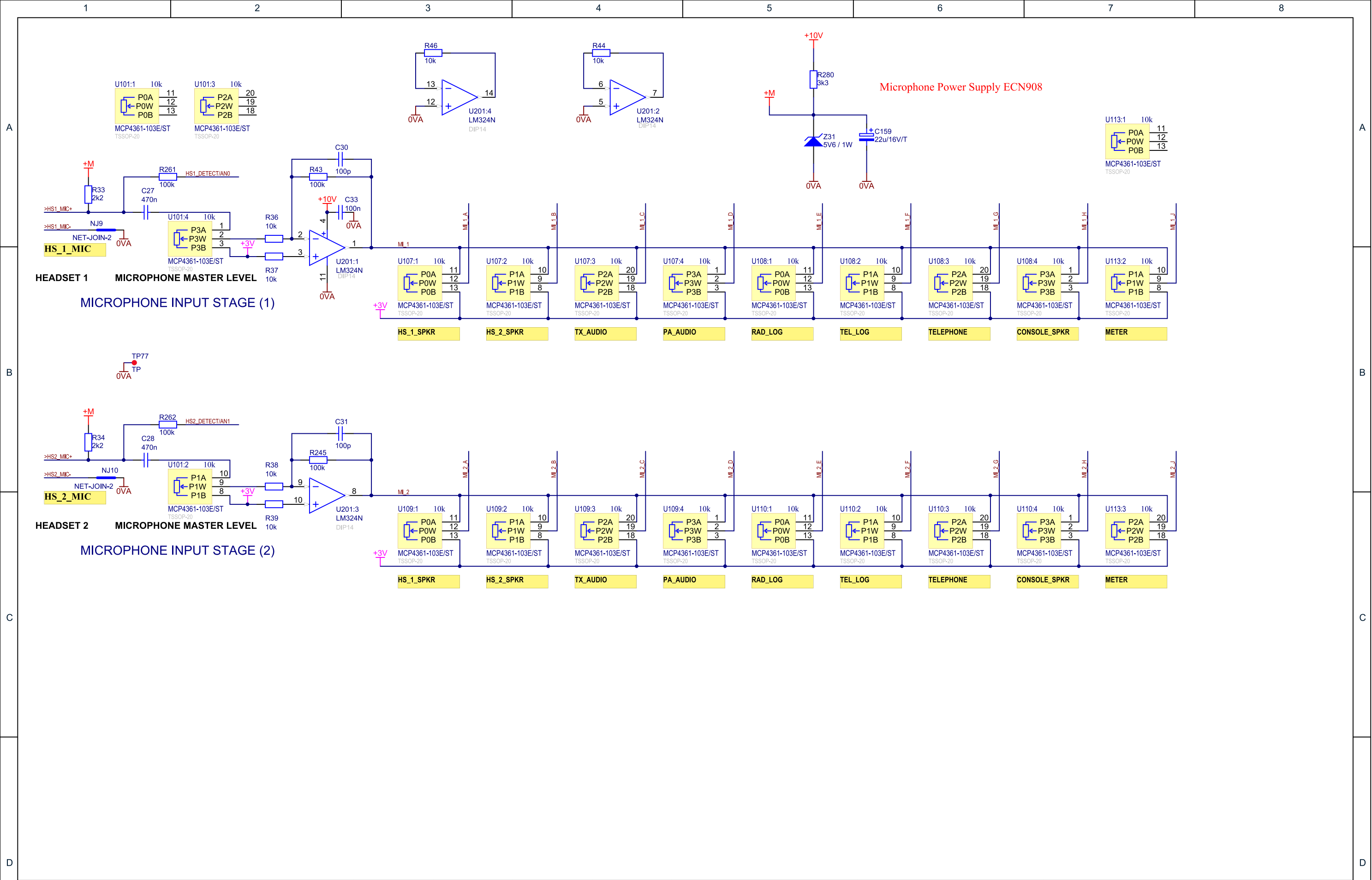

ISSUE	CHANGE DETAILS	POSITION	ECO No.	DRAWN	DATE	<b>DESIGN TWO THOUSAND PTY LTD</b> 9-11 Rose Street P.O. Box 7020 Upper Ferntree Gully Victoria Australia ABN 45 005 014 639	TITLE: <b>AMU RACK I/F - Mic Input</b>		
2	Mods for production release			ICT	25MAR2013		DWG No. <b>SC-525843</b>	REV <b>3</b>	SHEET 3 OF 10
3	Mods for production release			ICT	05APR2017		DATE 5/04/2017	CHKD	
							FILE SC-525843-3-MIC IN.SchDoc		

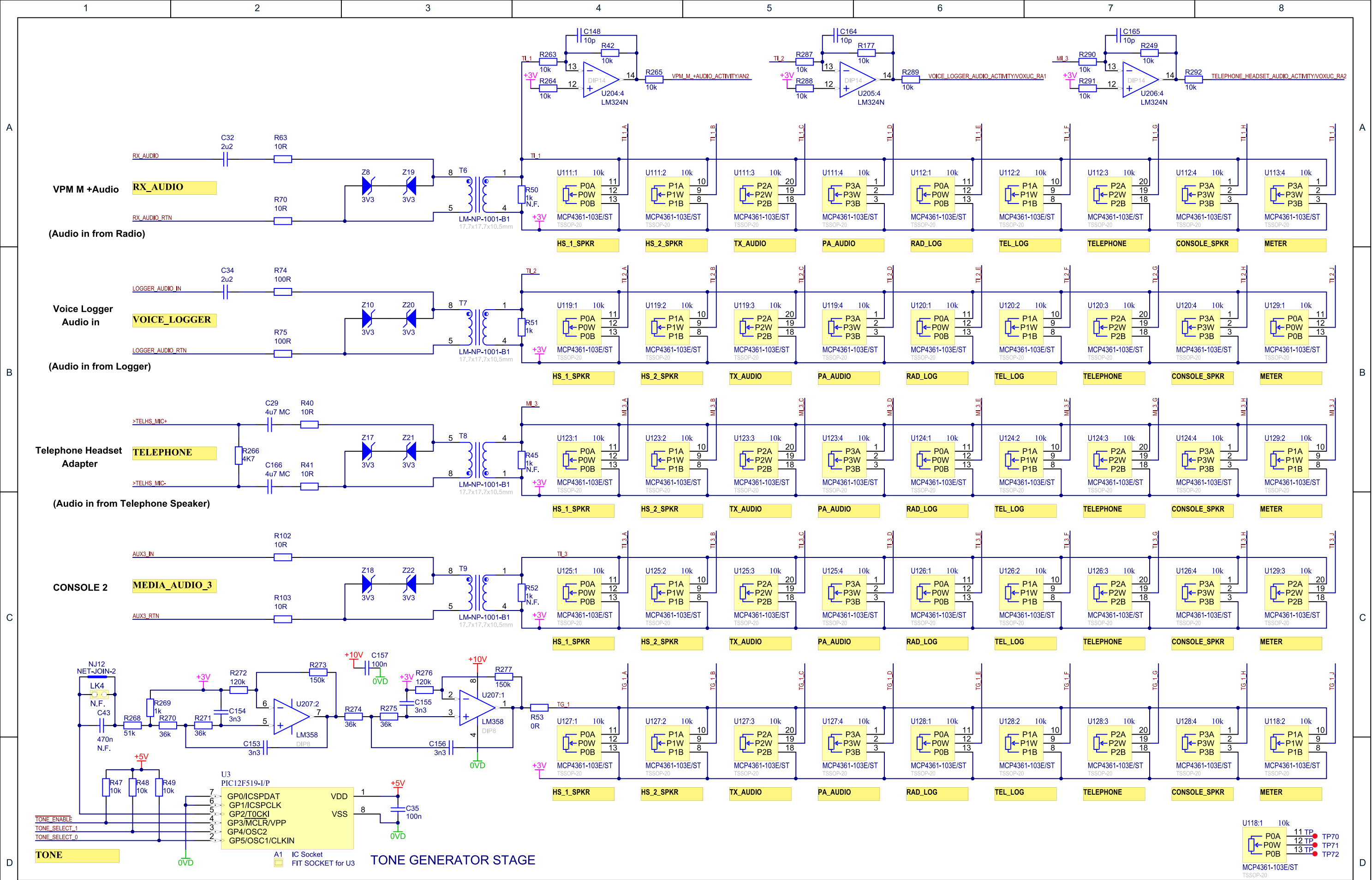

ISSUE	CHANGE DETAILS	POSITION	ECO No.	DRAWN	DATE
2	Mods for production release			ICT	25MAR2013
3	Mods for production release			ICT	05APR2017

**DESIGN TWO THOUSAND PTY LTD**  
 9-11 Rose Street  
 P.O. Box 7020  
 Upper Ferntree Gully  
 Victoria Australia  
 ABN 45 005 014 639

TITLE: <b>AMU RACK I/F - Tone Input</b>		
DWG No. <b>SC-525844</b>	REV <b>3</b>	SHEET <b>4</b> OF <b>10</b>
DATE <b>5/04/2017</b>	CHKD	
FILE <b>SC-525844-3-TONE IN.SchDoc</b>		

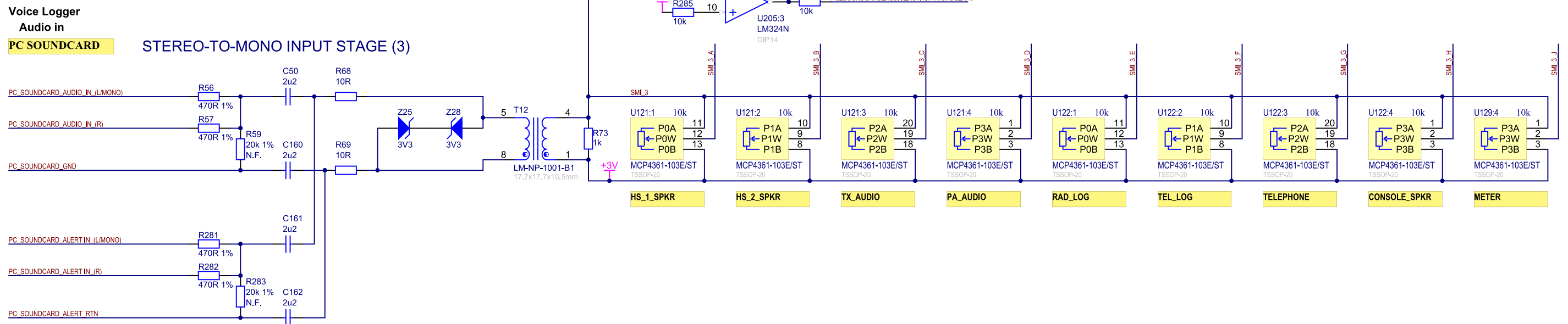
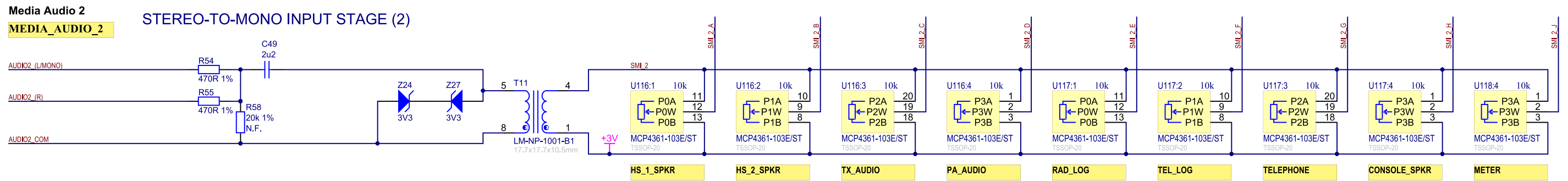
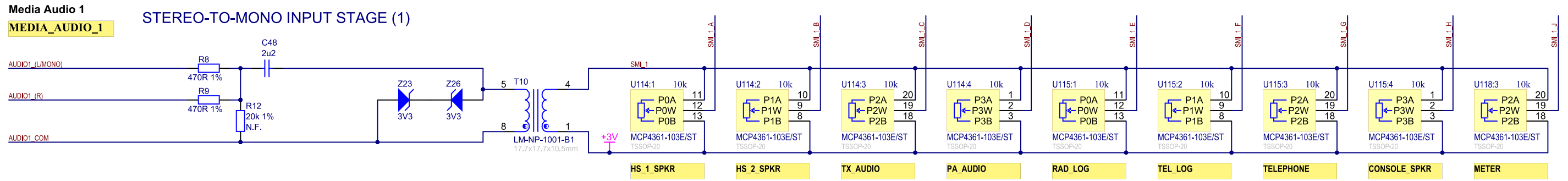

ISSUE	CHANGE DETAILS	POSITION	ECO No.	DRAWN	DATE
2	Mods for production release			ICT	25MAR2013
3	Mods for production release			ICT	05APR2017

**DESIGN TWO THOUSAND PTY LTD**  
 9-11 Rose Street  
 P.O. Box 7020  
 Upper Ferntree Gully  
 Victoria Australia  
 ABN 45 005 014 639

TITLE: <b>AMU RACK I/F - Stereo/Mono Audio In</b>		
DWG No. <b>SC-525845</b>	REV <b>3</b>	SHEET <b>5</b> OF <b>10</b>
DATE <b>5/04/2017</b>	CHKD	
FILE <b>SC-525845-3-STEREO-MONO AUDIO IN.SchDoc</b>		

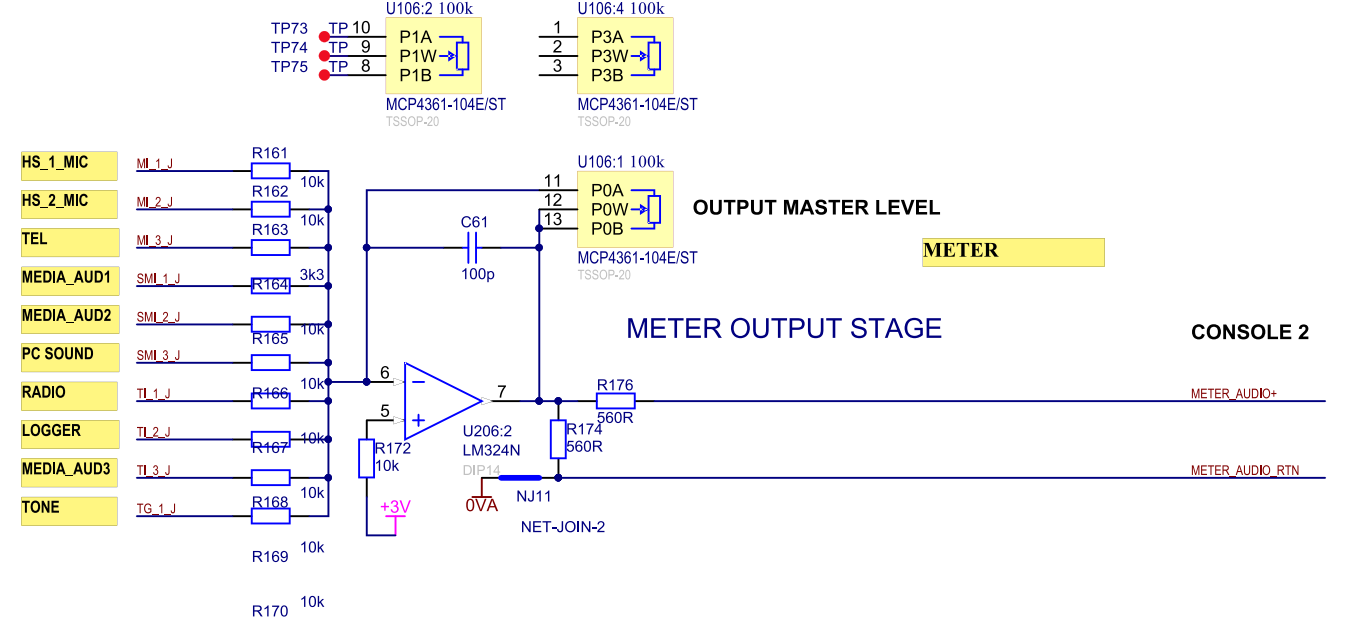
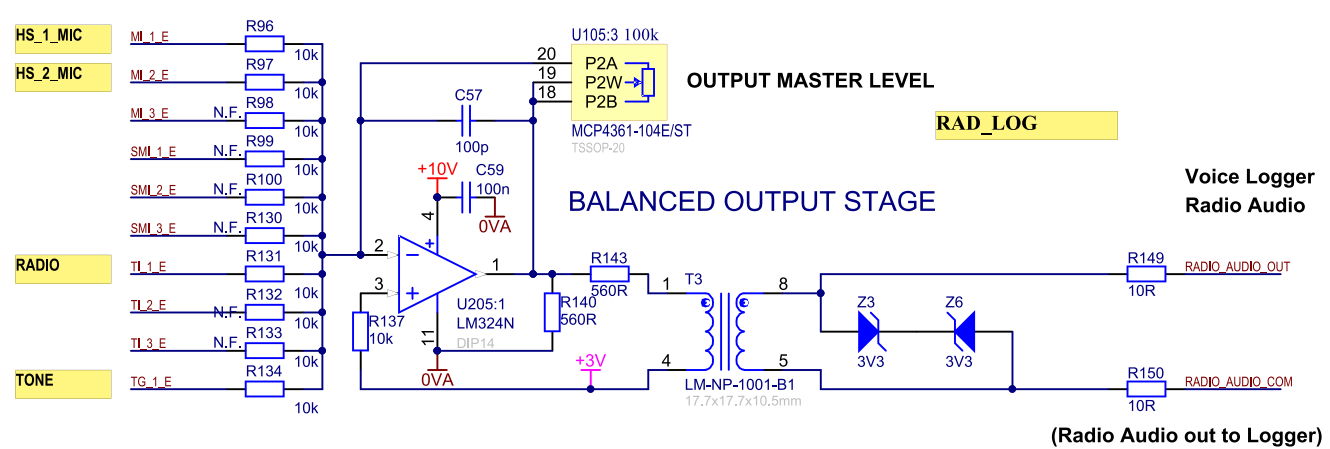
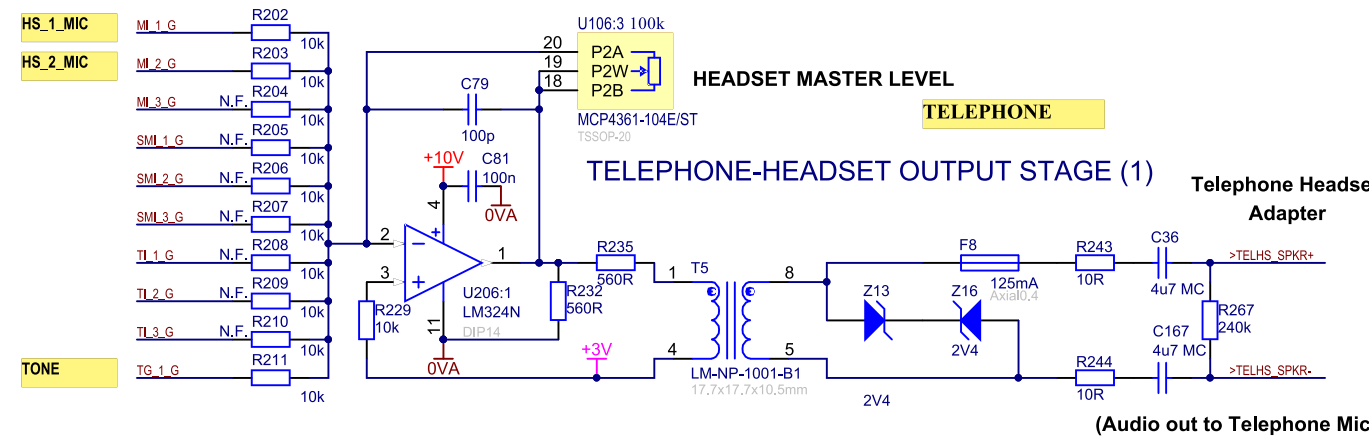
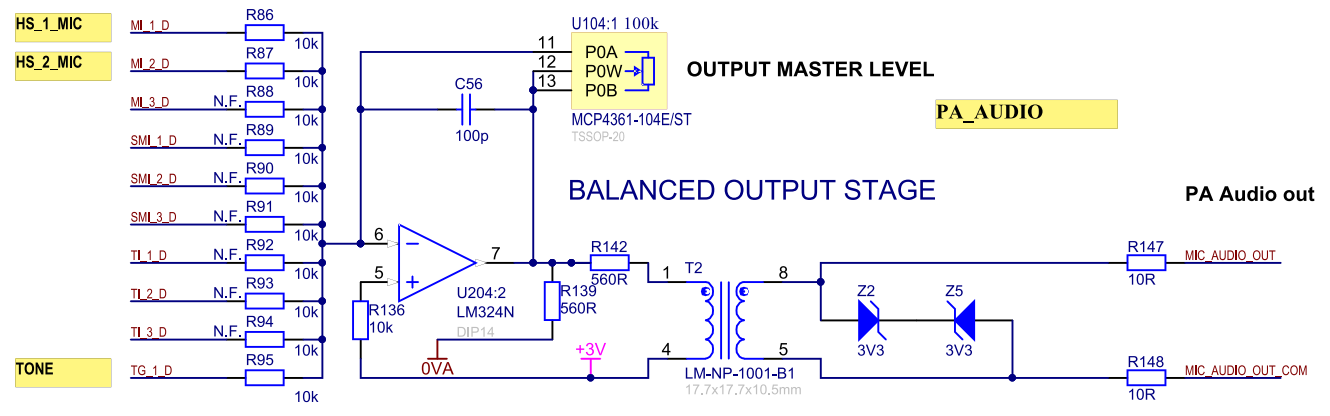
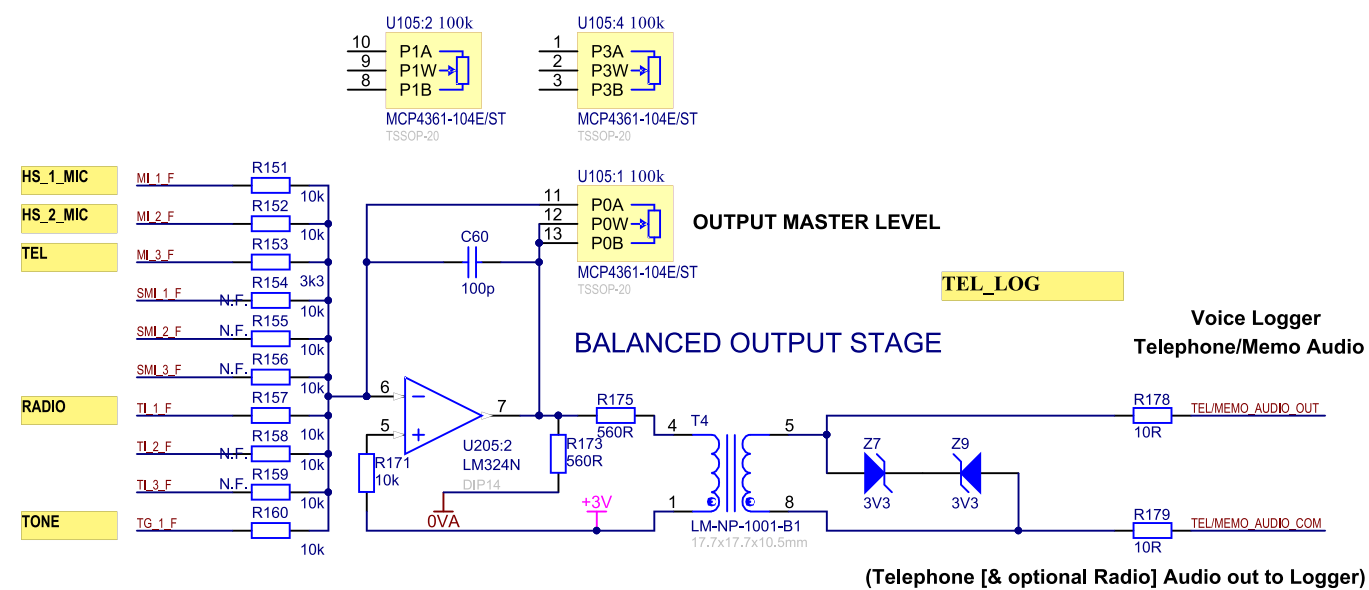
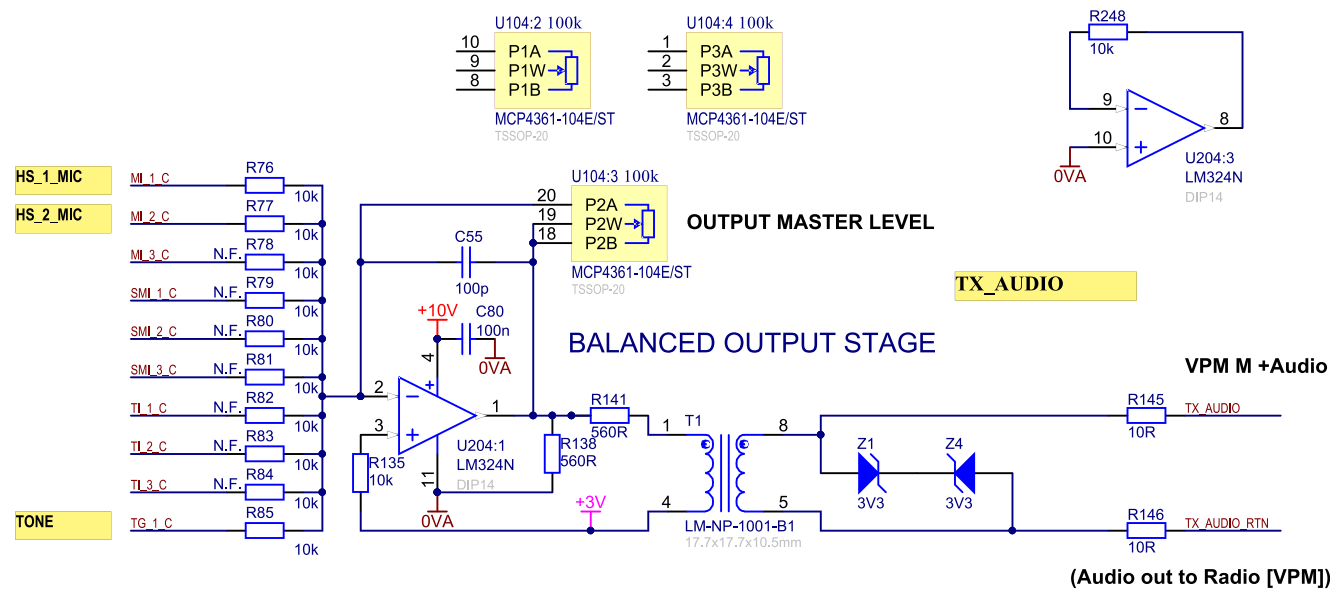

ISSUE	CHANGE DETAILS	POSITION	ECO No.	DRAWN	DATE
2	Mods for production release			ICT	25MAR2013
2a	Mods for ECN 919			RGK	31MAR2014
3	Mods for production release			ICT	05APR2017

<b>DESIGN TWO THOUSAND PTY LTD</b> 9-11 Rose Street P.O. Box 7020 Upper Ferntree Gully Victoria Australia ABN 45 005 014 639		TITLE: <b>AMU RACK I/F - Balance Line Out</b>	
DWG No. <b>SC-525846</b>	REV <b>3</b>	SHEET <b>6</b> OF <b>10</b>	
DATE <b>5/04/2017</b>	CHKD		
FILE <b>SC-525846-3-BAL-OUT.SchDoc</b>			

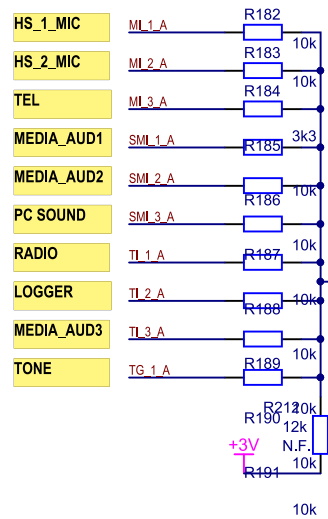

### HEADPHONE OUTPUT STAGE (1)

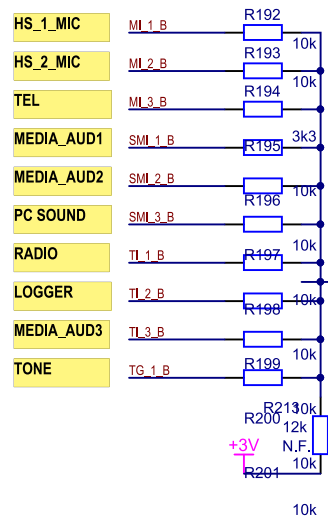
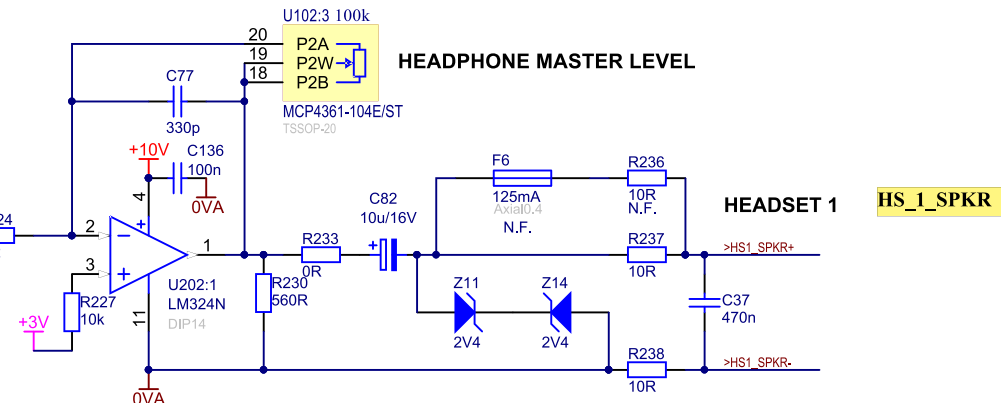

### HEADPHONE OUTPUT STAGE (2)

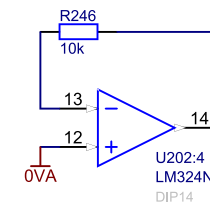
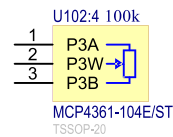
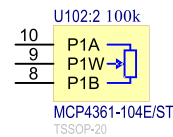
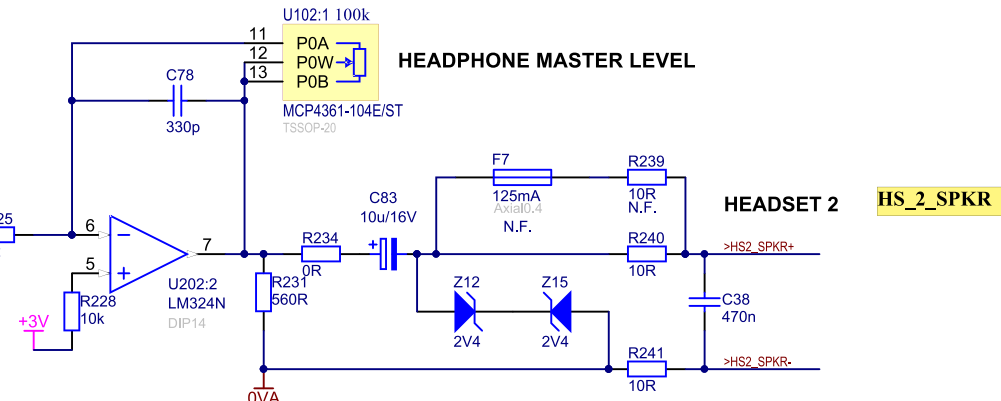

ISSUE	CHANGE DETAILS	POSITION	ECO No.	DRAWN	DATE	<b>DESIGN TWO THOUSAND PTY LTD</b> 9-11 Rose Street P.O. Box 7020 Upper Ferntree Gully Victoria Australia ABN 45 005 014 639	TITLE: <b>AMU RACK I/F - Headphone Output</b>		
2	Mods for production release			ICT	25MAR2013		DWG No. <b>SC-525847</b>	REV <b>3</b>	SHEET <b>7</b> OF 10
3	Mods for production release			ICT	05APR2017		DATE 5/04/2017	CHKD	
							FILE SC-525847-3-HEADPHONE-OUT.SchDoc		

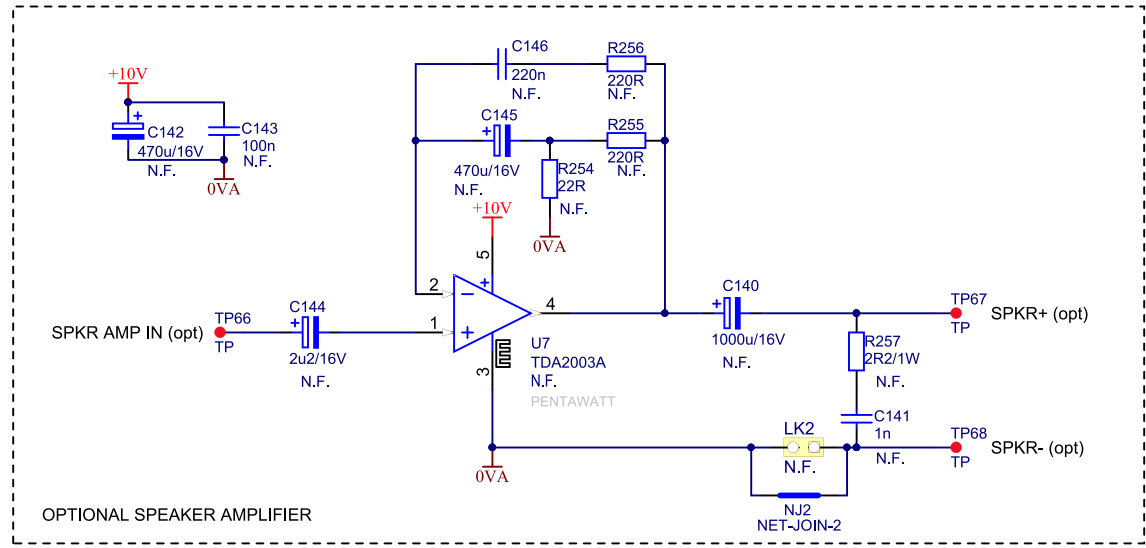
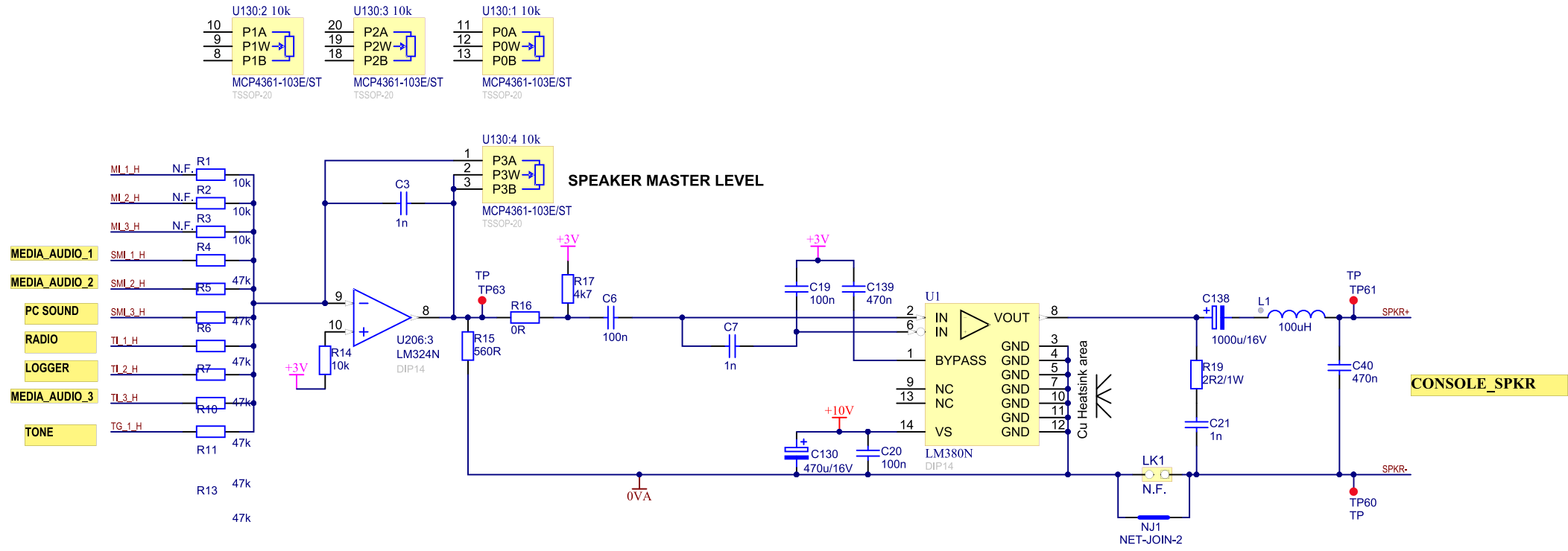

ISSUE	CHANGE DETAILS	POSITION	ECO No.	DRAWN	DATE	<b>DESIGN TWO THOUSAND PTY LTD</b> 9-11 Rose Street P.O. Box 7020 Upper Ferntree Gully Victoria Australia ABN 45 005 014 639	TITLE: <b>AMU RACK I/F - Speaker Driver Out</b>		
2	Mods for production release			ICT	25MAR2013		DWG No. <b>SC-525848</b>	REV <b>3</b>	SHEET 8 OF 10
3	Mods for production release			ICT	05APR2017		DATE 5/04/2017	CHKD	
							FILE SC-525848-3-SPKR-OUT.SchDoc		

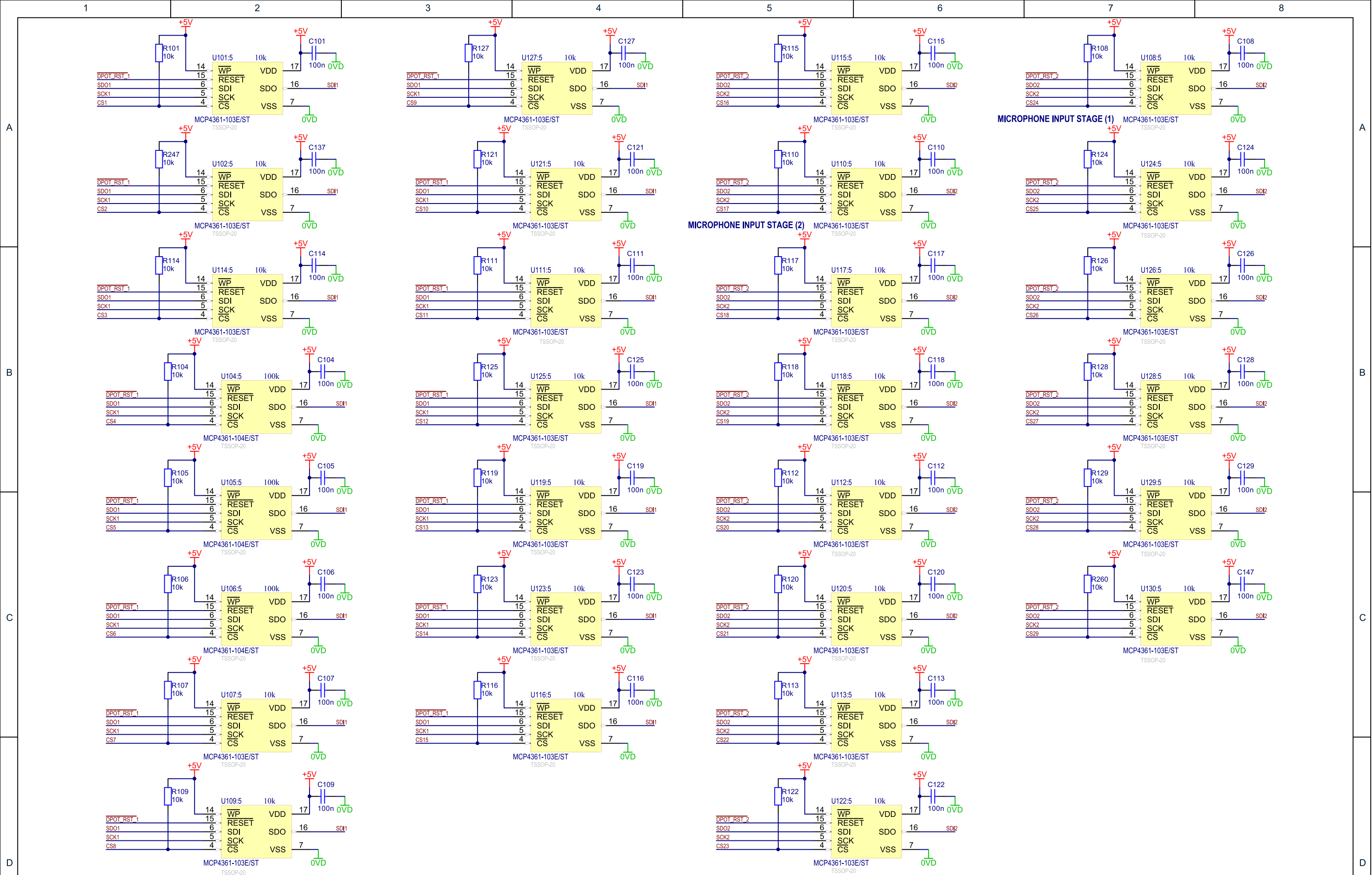

ISSUE	CHANGE DETAILS	POSITION	ECO No.	DRAWN	DATE	<b>DESIGN TWO THOUSAND PTY LTD</b> 9-11 Rose Street P.O. Box 7020 Upper Ferntree Gully Victoria Australia ABN 45 005 014 639	TITLE:			
2	Mods for production release			ICT	25MAR2013		<b>AMU RACK I/F - Digital POT Mixer</b>			
3	Mods for production release			ICT	05APR2017		DWG No.	SC-525849	REV 3	SHEET 9 OF 10
							DATE	5/04/2017	CHKD	
							FILE	SC-525849-3-DIGPOT.SchDoc		

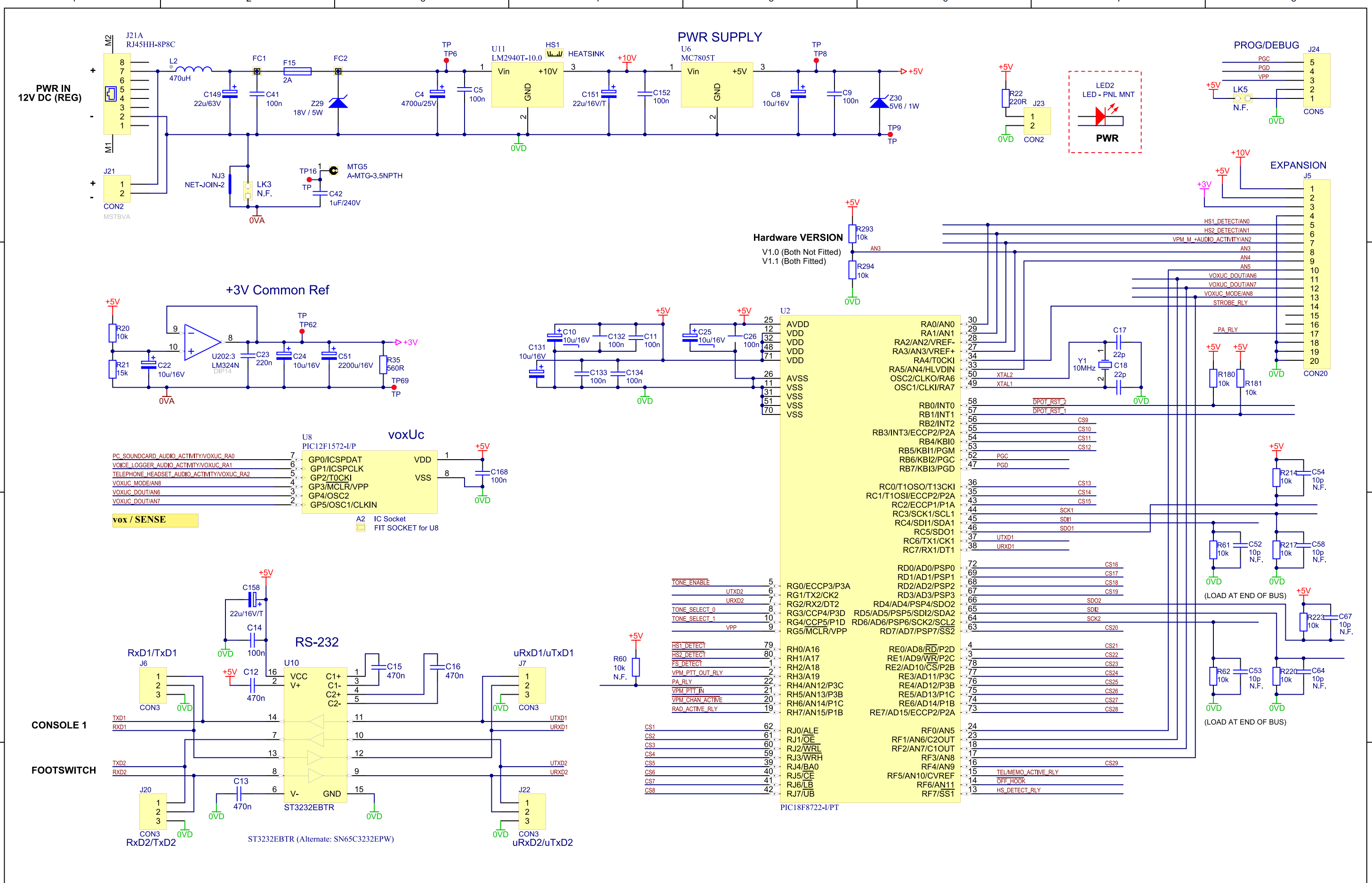

ISSUE	CHANGE DETAILS	POSITION	ECO No.	DRAWN	DATE	DESIGN TWO THOUSAND PTY LTD 9-11 Rose Street P.O. Box 7020 Upper Ferntree Gully Victoria Australia ABN 45 005 014 639	TITLE: <b>AMU RACK I/F - Processor &amp; Comms</b>		
2	Mods for production release			ICT	25MAR2013		DWG No. <b>SC-5258410</b>	REV <b>3</b>	SHEET 10 OF 10
3	Mods for production release			ICT	05APR2017		DATE 5/04/2017	CHKD	
							FILE SC-5258410-3-PROCESSOR.SchDoc		





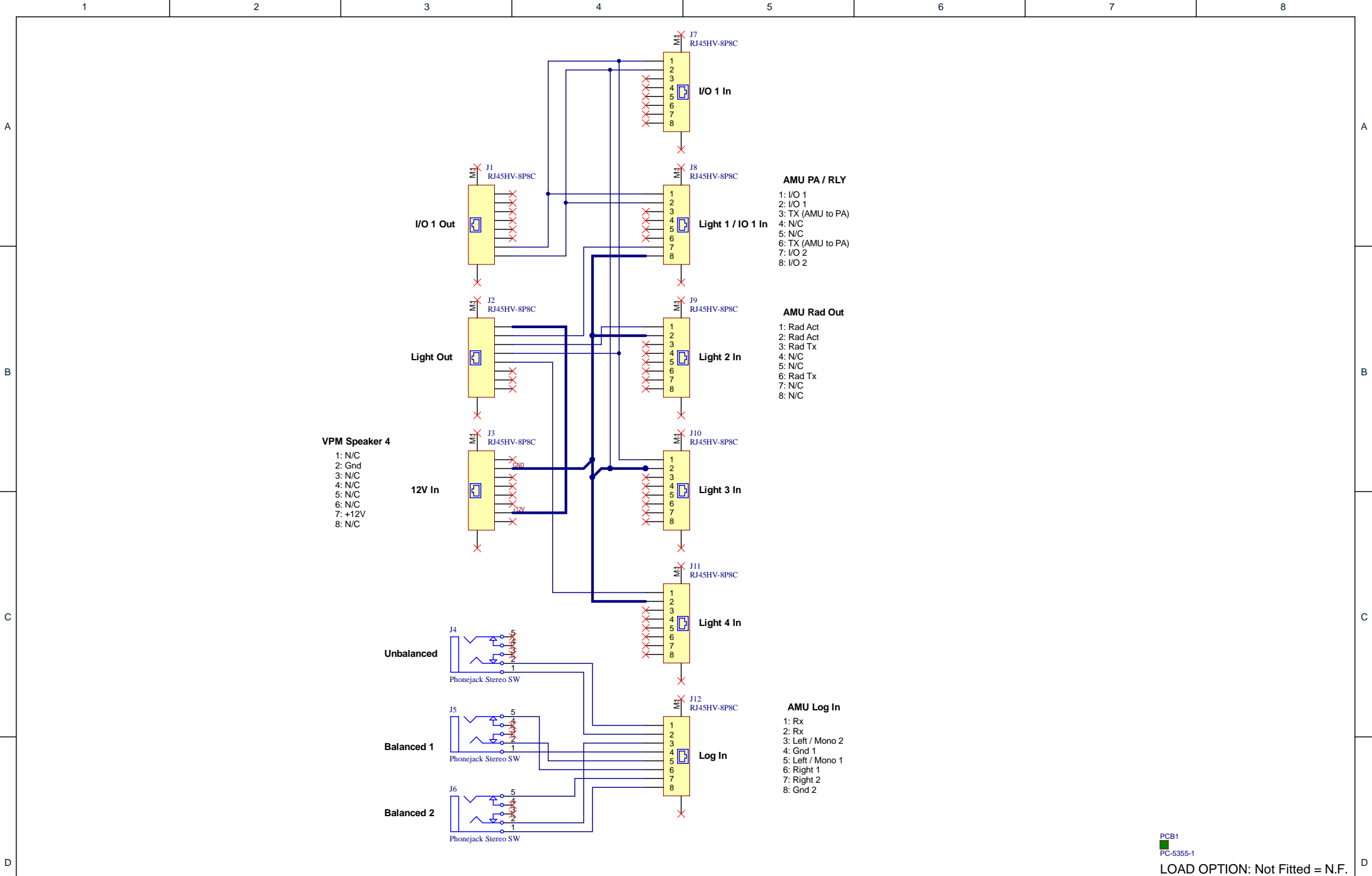

PCB1  
PC-5355-1

LOAD OPTION: Not Fitted = N.F.

ISSUE	CHANGE DETAILS	POSITION	ECO No.	DRAWN	DATE
1	Proto release			ICT	26JUL2017
2	J10 Pin 1 to J7 Pin 1			AZ	3JUL2018
3	J10 Pin 2 to J7 Pin 2			AZ	3JUL2018

**DESIGN TWO THOUSAND PTY LTD**  
**9-11 Rose Street**  
 P.O. Box 7020  
 Upper Ferntree Gully  
 Victoria Australia  
 ABN 45 005 014 639

TITLE:		
<b>IB AMU Light Tower (5355)</b>		
DWG No. <b>SC-53554</b>	REV <b>3</b>	SHEET <b>1</b> OF <b>1</b>
DATE <b>3/07/2018</b>	CHKD	
FILE <b>SC-53554-3.SchDoc</b>		